

 **MISUTONIDA**
  *italian style* **4x4**
accessories

RENAULT TRAFIC



Item Code

Codice Articolo

: TPS/251/IX

Référence Article

GB

STAINLESS STEEL
SIDE PROTECTIONS

ITA











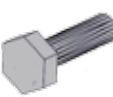

TUBI PROTEZIONE
SOTTOPORTA IN ACCIAIO INOX

FR

**PROTECTIONS LATERALES
EN ACCIER INOX**

RENAULT TRAFIC

Part List
 Lista della bulloneria
 Liste des pièces

A	P/152/P	L	P/152/A
	x 6		x 2
B	TE 10x30	M	TPS/251/B
	x 6		x 6
C	M 10	N	TPS/251/C
	x 6		x 2
D	Ø 10		
	x 12		
E	Ø 10		
	x 12		
F	TE 8x25		
	x 8		
G	Ø 8 GRAND BIG GRAND		
	x 10		
H	Ø 8		
	x 10		
I	M8		
	x 10		

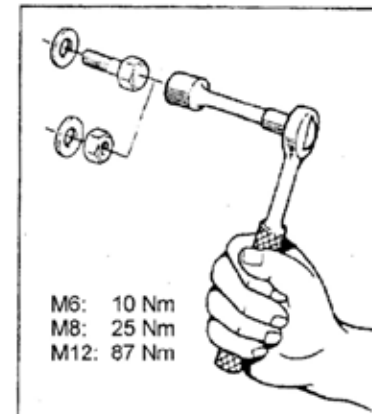
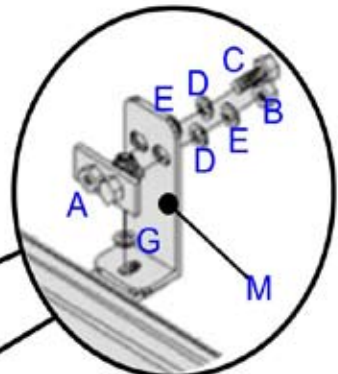
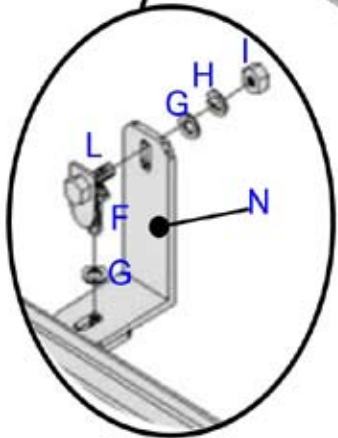
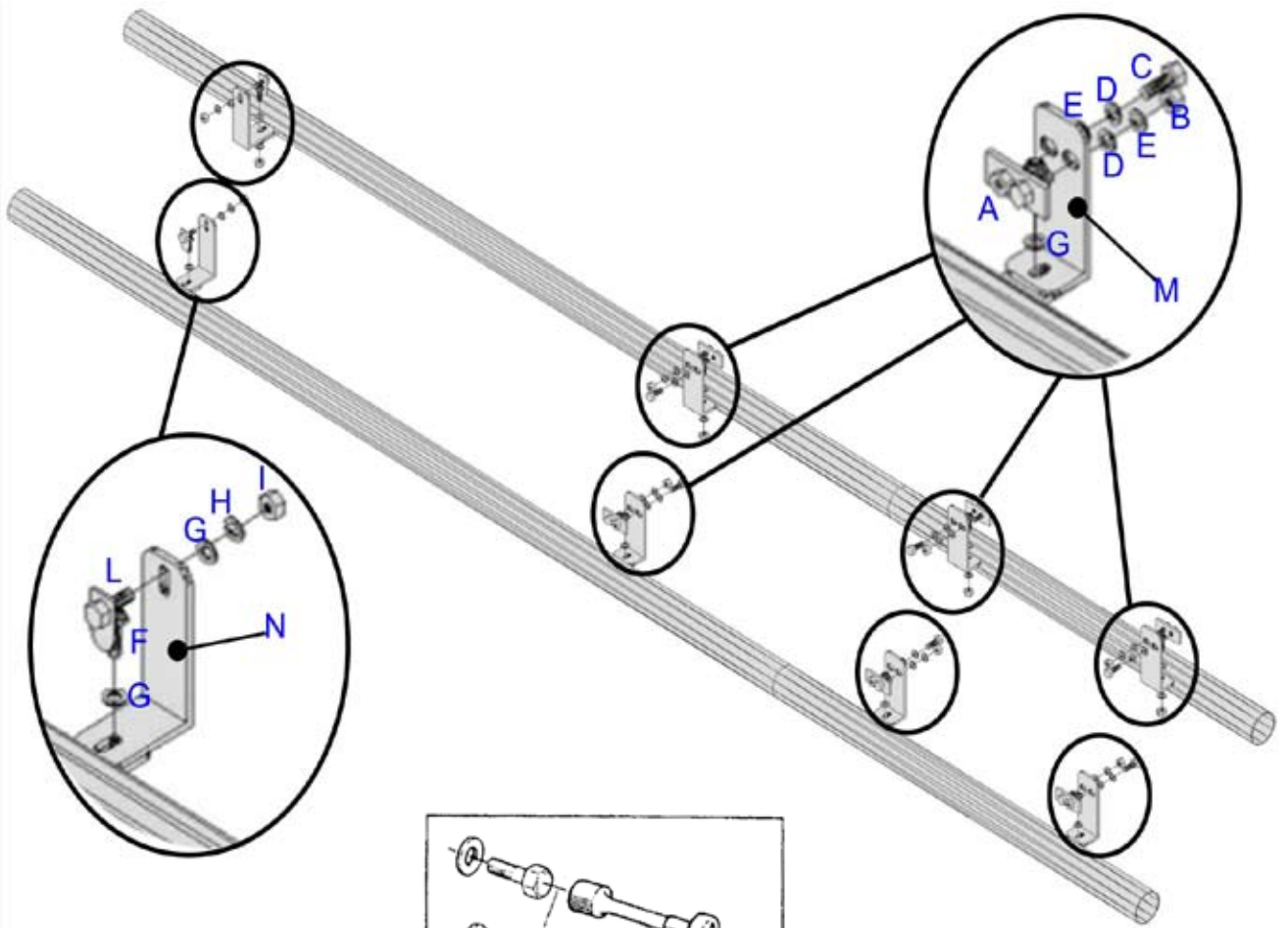

GB**FITTING
INSTRUCTIONS****FRONT SIDE**

1. Remove the plastic caps located in the front side (picture 1).

2. Insert A in the hole shown in picture 2.

WARNING: make sure it doesn't fall inside the bodywork!

3. Fit the M brackets on A using B,C,D,E as shown in pictures 3 and 4.

Do not tighten the set of bolts!

REAR SIDE

4. Remove the plastic caps located in the rear side.

5. Insert L,H,I,G (in order to avoid the falling inside the bodywork) in the hole shown in picture 5.

6. Fit the N bracket as shown in picture 6 and fix it to the chassis using H,I,L.

Do not tighten the set of bolts!

7. Insert the front pipe in the rear pipe as shown in picture 6 and fit the accesoryon the M and N brackets using F,G,H,I.

8. Tighten all the set of bolts.

ITA**ISTRUZIONI DI
MONTAGGIO****PARTE ANTERIORE**

1. Rimuovere i tappi in plastica situati nella parte anteriore (foto 1).

2. Inserire A nel foro indicato in foto 2
ATTENZIONE a non fare cadere A all'interno del telaio!

3. Montare le staffe M su A utilizzando B,C,D,E come indicato in foto 3,4.

Non serrare la bulloneria!

PARTE POSTERIORE

4. Rimuovere i tappi in plastica situati nella parte posteriore.

5. Inserire L,H,I,G (per evitare che cada all' interno del telaio) nel foro indicato in foto 5.

6. Montare la staffa N come indicato in foto 6 fissarla al telaio utilizzando H,I,L.

Non serrare la bulloneria

7. Fissare l'accessorio infilando il tubo anteriore in quello posteriore come indicato in foto 6 e fissarlo alle staffe M e N utilizzando F,G,H,I.

8. Serrare tutta la bulloneria.

FR**INSTRUCTIONS DE
MONTAGE****PARTIE ANTERIEURE**

1. *Enlever les bouchons en plastique qui se trouvent dans la partie antérieure (photo 1).*

2. *Insérer A dans le trou indiqué dans la photo 2.*

ATTENTION *qu'il ne tombe pas à l'intérieur du châssis!*

3. *Monter les pattes de fixations M sûr A en utilisant B,C,D,E comme indiqué dans les photos 3 et 4.*

Ne pas serrer la boulonnerie!

PARTIE POSTERIEURE

4. *Enlever les bochons en plastique qui se trouvent dans la partie postérieure.*

5. *Insérer L,H,I,G dans le trou indiqué en photo 5 (en faisant attention qu'ils ne tombent pas à l'intérieur du châssis).*

6. *Monter N comme indiqué en photo 6 et la fixer au châssis en utilisant H,I,L.*

Ne pas serrer la boulonnerie!

7. *Monter l'accessoire en infilant le tube antérieur dans le tube posterior comme indiqué dans la photo 6 et le fixer à le pattes de fixation M et N en utilisant F,GH,I.*

8. *Serrer toute la boulonnerie.*

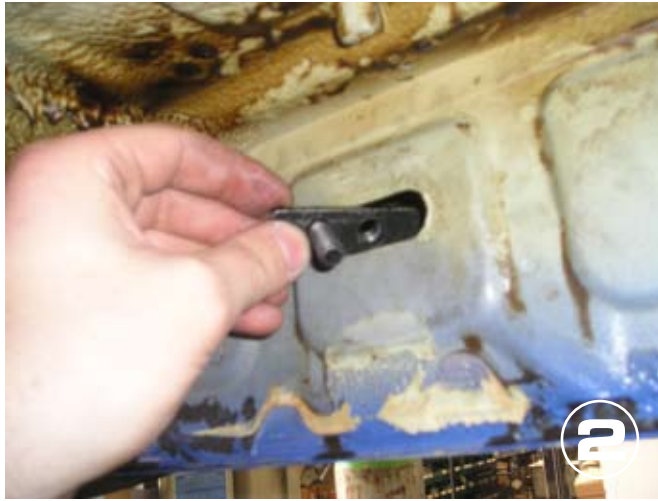

Date Data Date	Item Code Cod.Articolo Réf. Article	Vehicle model Modello Veicolo Modèle de Voiture
23/07/09	TPS/251/IX	RENAULT TRAFIC

Document checked and approved by
Documento controllato ed approvato da
Document contrôlé et approuvé par

**Botta
Pietro**

