

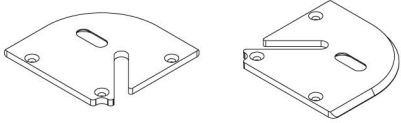

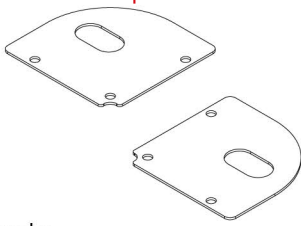
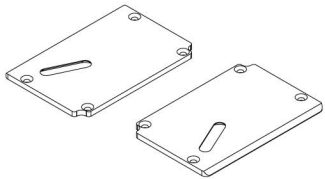
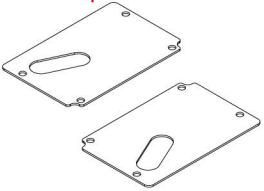
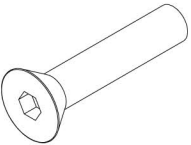
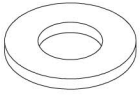

UpStoneEvolve

INSTRUCTIONS DE MONTAGE K429 FORD RANGER 2012+ DC/XC AVEC ARCEAU D'ORIGINE

A  Droite + Gauche 2X	B Pré-collé sur pièces A  Droite + Gauche 2X	C  Droite + Gauche 2X
D Pré-collé sur pièces C  Droite + Gauche 2X	E  M6X30mm 14X	F  M6X13mm 14X
G  M6 14X	H  M8x15mm 4X	

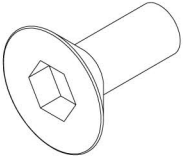
-  - Nouveau composant
-  - Composant existant

Note 1 : Ce kit a été conçu pour le tonneau cover alu Upstone Evolve pour Ford Ranger 2012+ double et super cabine, compatible avec l'arceau inox d'origine uniquement

Note 2 : Si lors de l'installation du cover vous avez des questions concernant son installation, contactez Marina 4x4 Accessoires pour plus de renseignements.

OUTILS NÉCESSAIRES



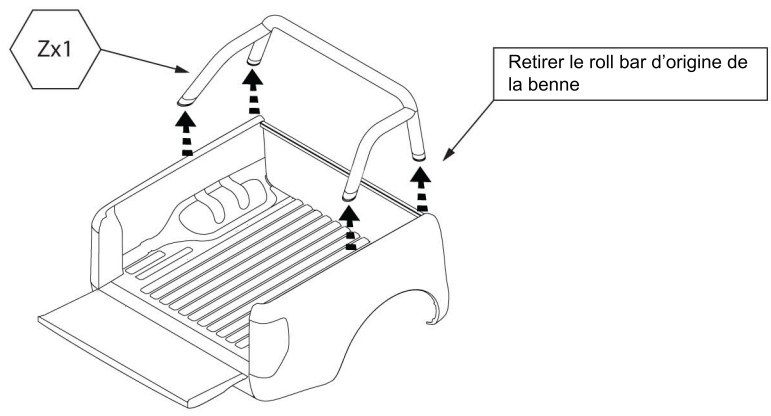

1

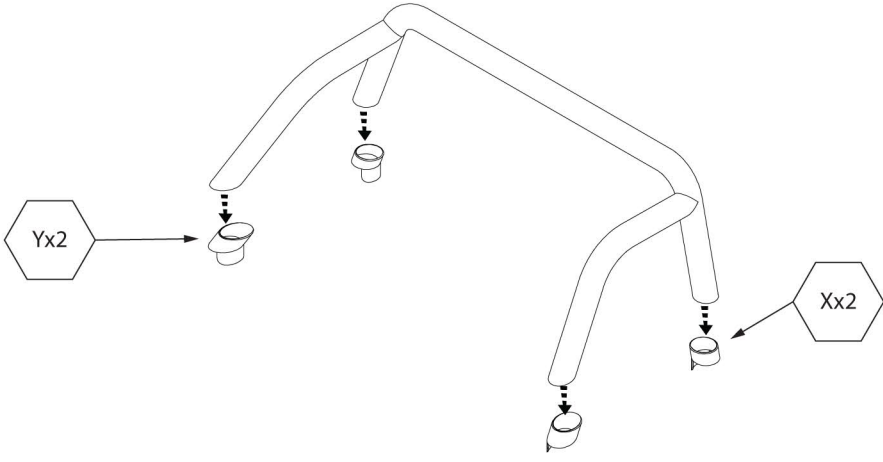

2

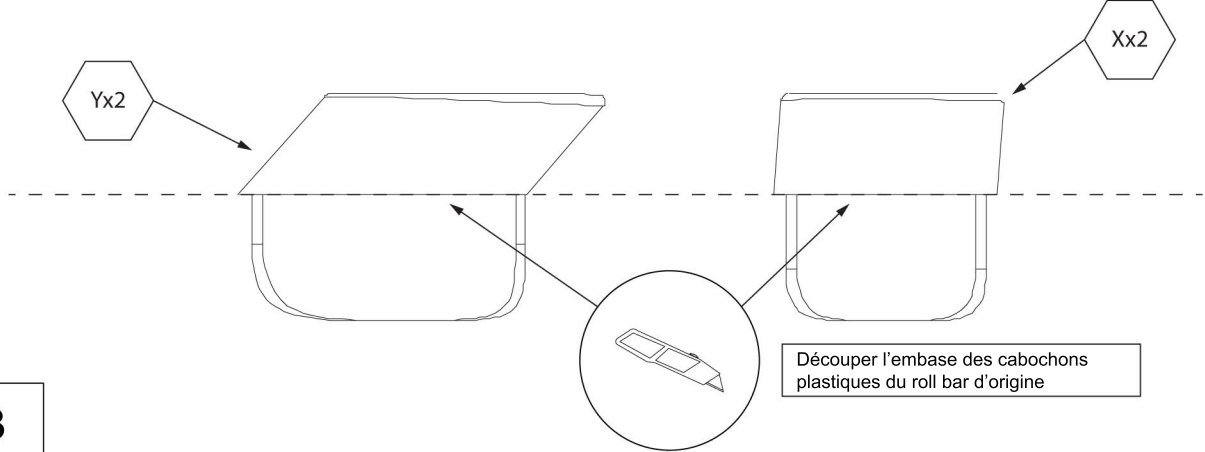

3

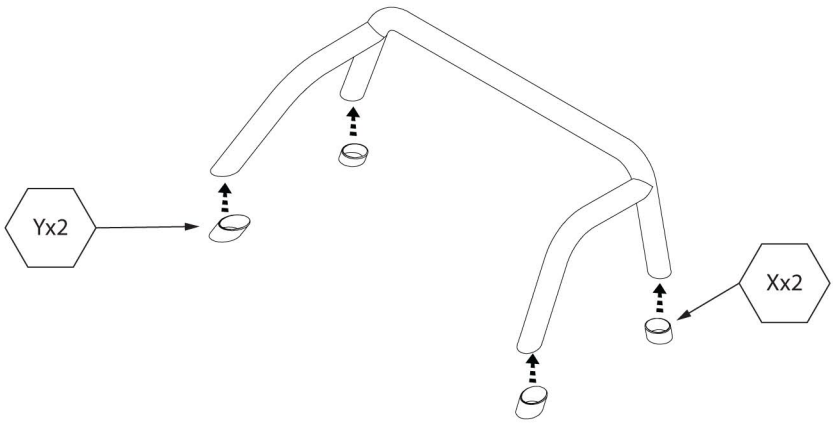

4

Fitting Kit Number	Product	Revision	Date	Page
K429	Ford OE Bar	1	15.01.16	2 of 4

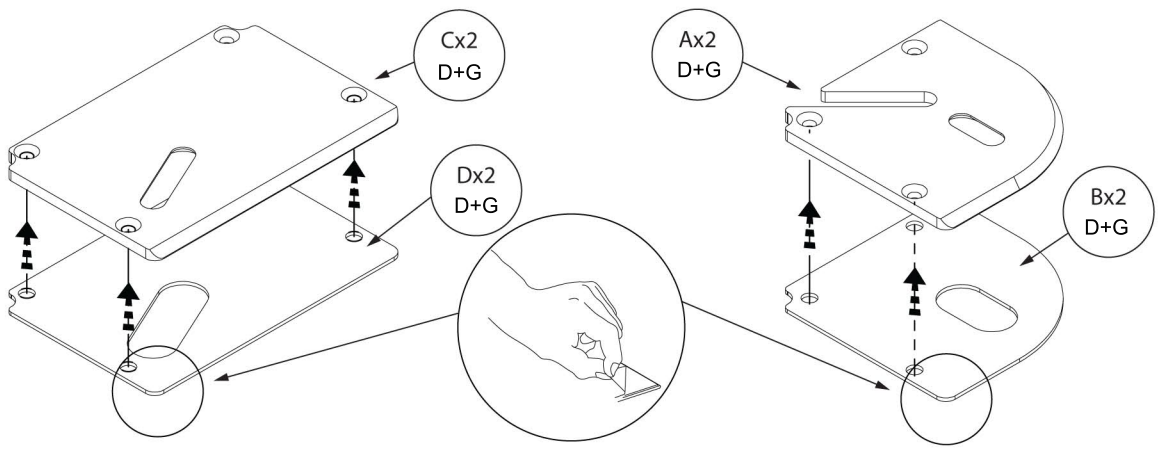

5

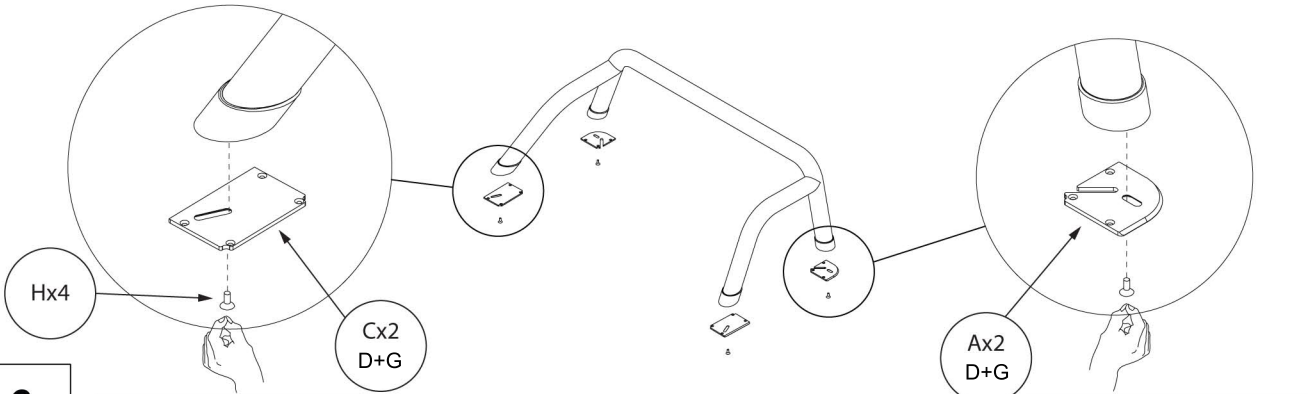

6

Serrage manuel uniquement

Serrage manuel uniquement

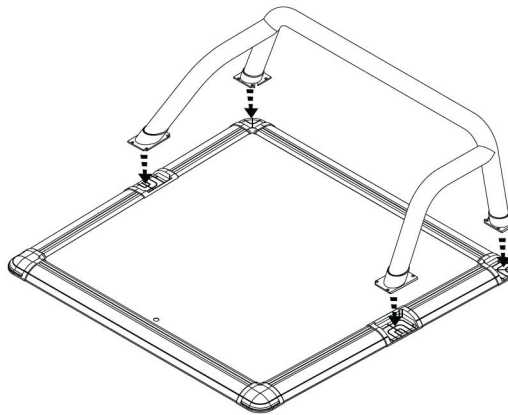

7

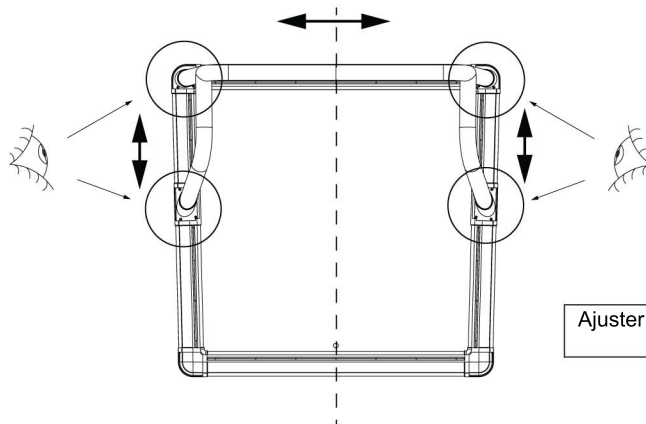

Ajuster l'emplacement de l'arceau

8

Fitting Kit Number

Product

Revision

Date

Page

K429

Ford OE Bar

1

15.01.16

3 of 4

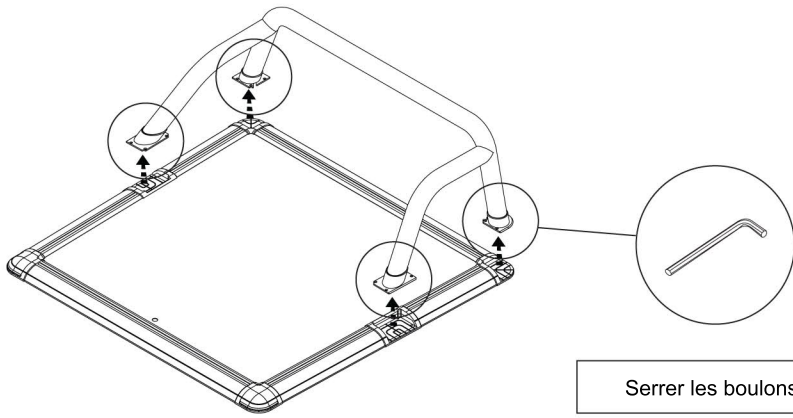

9

Serrer les boulons

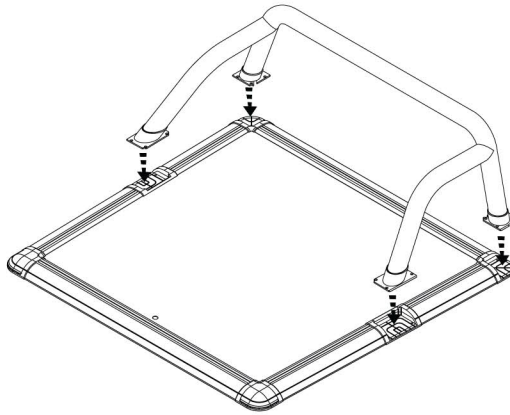

10

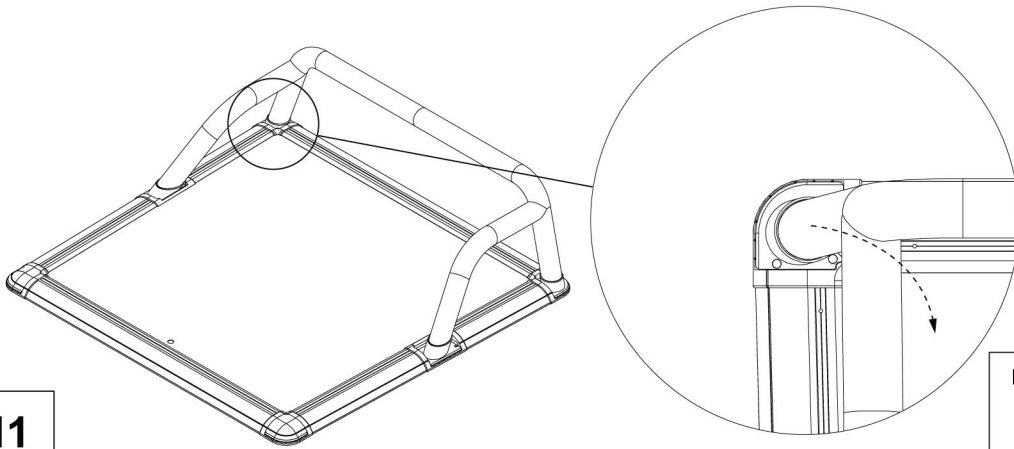

11

Passer le câble du 3e feu stop dans le trou percé à cet effet puis dans le cover

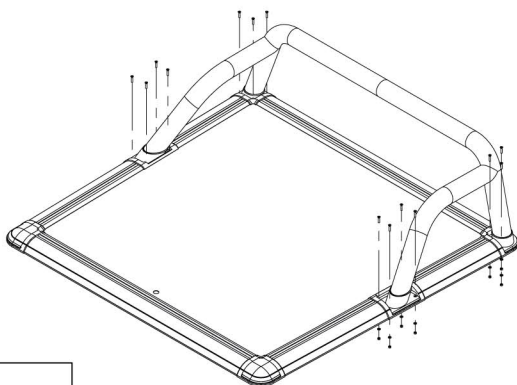

12

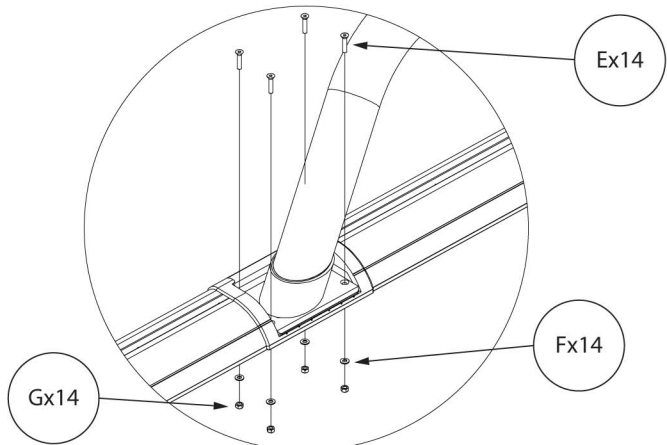

Gx14











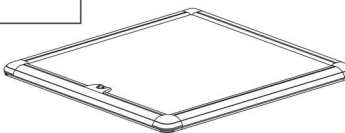
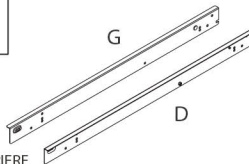
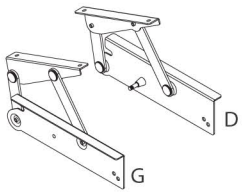
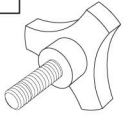

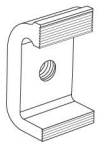
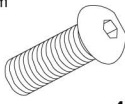

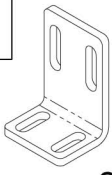

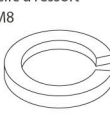
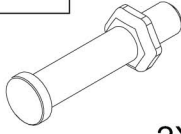
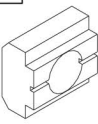
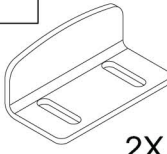
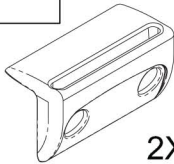



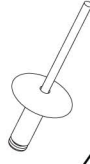
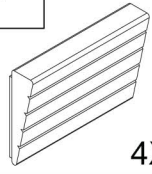
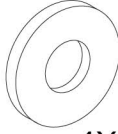

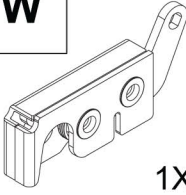
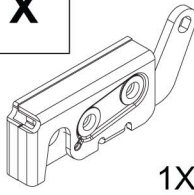
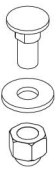
Ex14

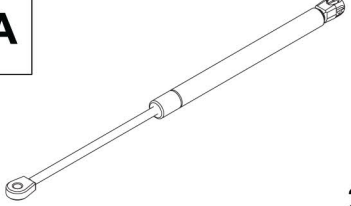
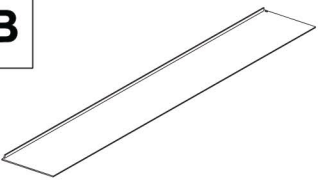
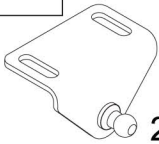
Fx14

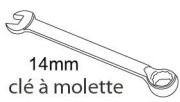
Fitting Kit Number	Product	Revision	Date	Page
K429	Ford OE Bar	1	15.01.16	4 of 4

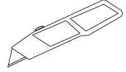
UpStoneEvolve

NOTICE DE MONTAGE - KIT K408

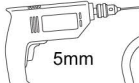
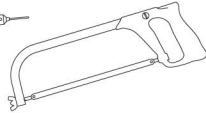
A  1X	B  ARRIERE 1X	C  1X	D  2X		
E  2X	F  4X	G M8x25mm  4X	H M8 x16 Rondelle inox  6X	I  2X	J Ecrou nylock M8  4X
K Rondelle à ressort inox M8  2X	L  2X	M  2X	N  2X	O  2X	P M6x18  16X
Q M6x13mm Zinc  12X	R M6x10mm  12X	S  4X	T  4X	U M10x24mm  4X	V M8 x16 Rondelle zinc  8X
W Côté droit  1X	X Côté gauche  1X	Y Boulon pour câbles, rondelle et écrou borgne  2X	Z  2X	AA  2X	
AB  1X	AC  2X	<p>Remarque : Il est préférable d'installer le tonneau cover avec un bac de benne SANS REBORDS TOUT MONTAGE AVEC BAC DE BENNE AVEC REBORDS N'EST PAS RECOMMANDE !</p> <p>Outils nécessaires</p>  4mm & 5mm clé Allen  14mm clé à molette   			
 OPTIONNEL   5mm 					
Kit de montage K408	Article Tonneau cover UpStone	Revision 1	Date 01.07.2016	Page 1 sur 7	

1

Démontez le porte-échelle

Remarque : Il est préférable d'installer le tonneau cover avec un bac de benne SANS REBORDS

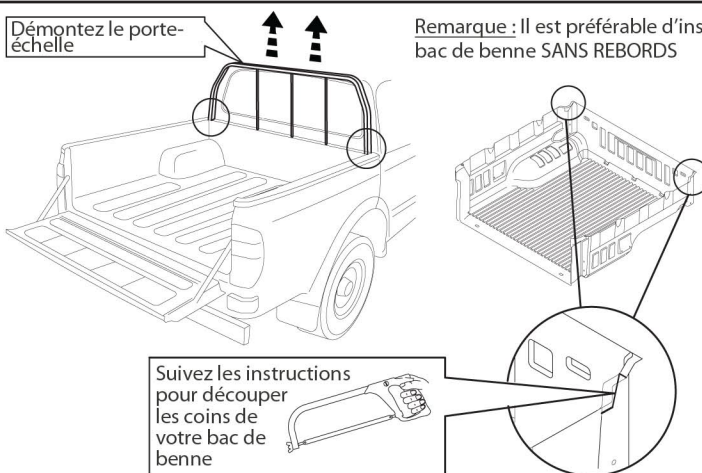

Suivez les instructions pour découper les coins de votre bac de benne

2

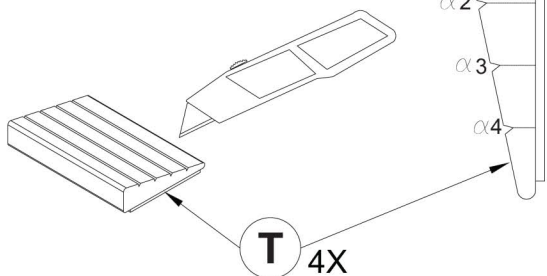
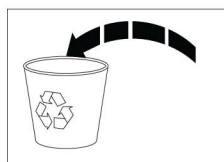

Modèle véhicule	α
Isuzu D-Max Double & Extra Cab 2012	non nécessaire
Volkswagen Amarok Double Cab 2010	1
Ford Ranger T6 Double & Extra Cab 2011	2
Mitsubishi L200 Double Cab Long Bed 2009/2015	3
Nissan Navara NP300 2016 Double & King Cab	2

3

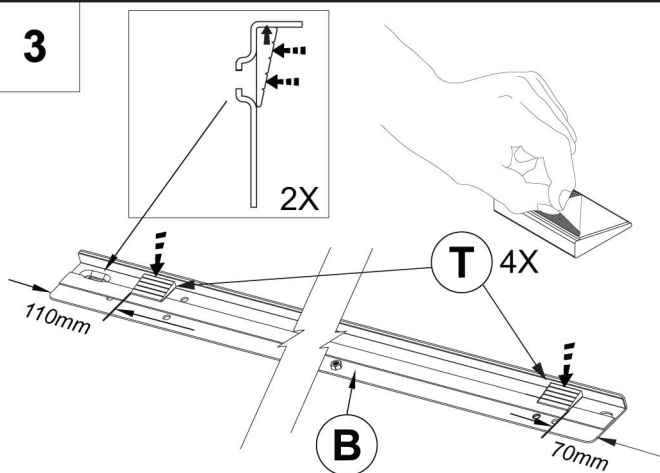

4

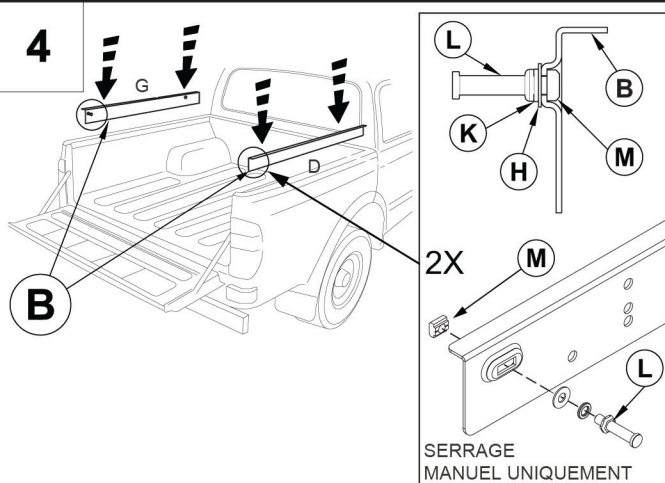

5

A l'avant des rails, placez le crochet sur la face arrière du rail - voir tableau pour les mesures

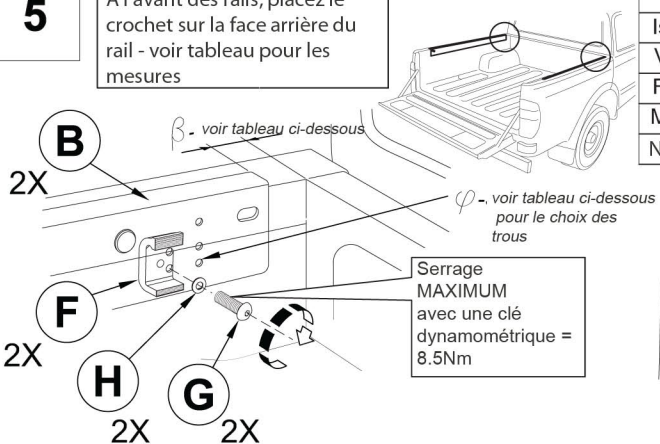

Modèle véhicule	β	δ	φ
Isuzu D-Max Double & Extra Cab 2012	69mm	1	4
Volkswagen Amarok Double Cab 2010	70.4mm	3	1
Ford Ranger T6 Double & Extra Cab 2011	72.4mm	4	3
Mitsubishi L200 Double Cab Long Bed 2009	70.4mm	4	2
Nissan Navara NP300 2016 Double & King Cab	80mm	1	7

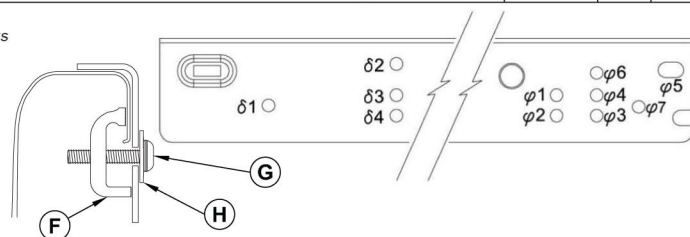

Kit de montage

Article

Revision

Date

Page

K408

Tonneau cover UpStone

1

01.07.2016

2 sur 7

6

δ - Voir tableau page 2 pour le choix des trous

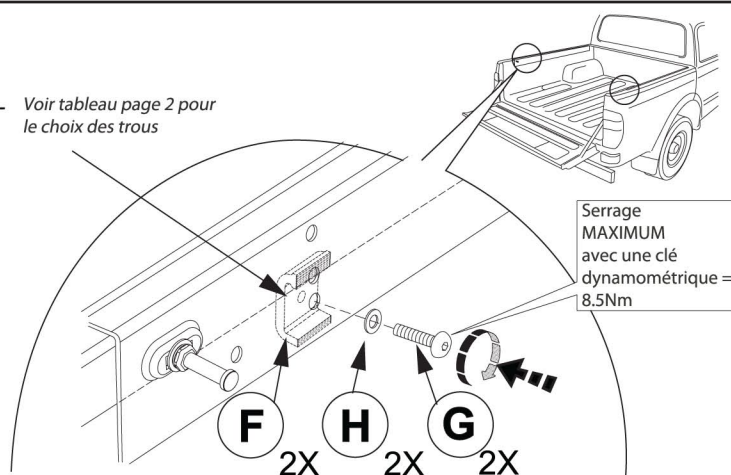

7

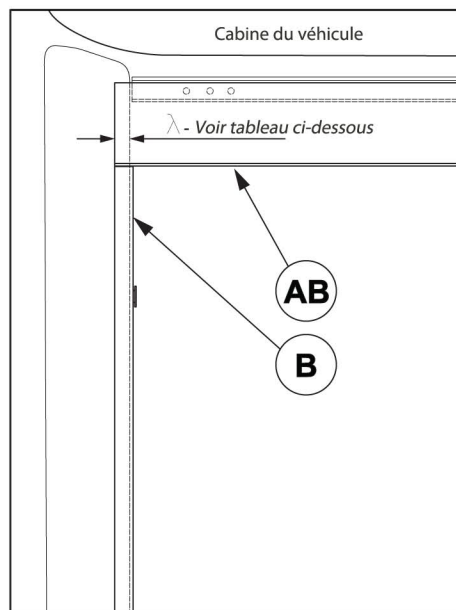
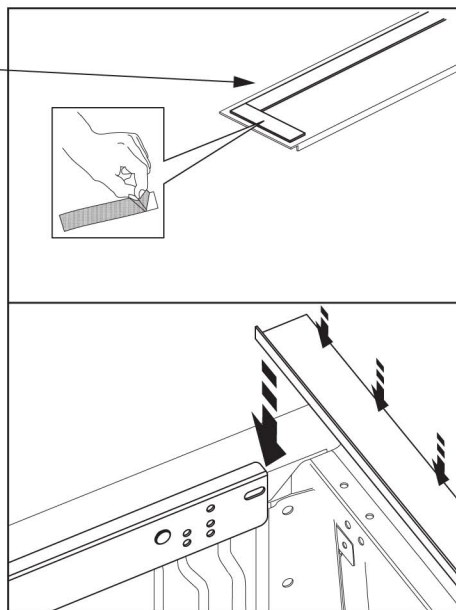
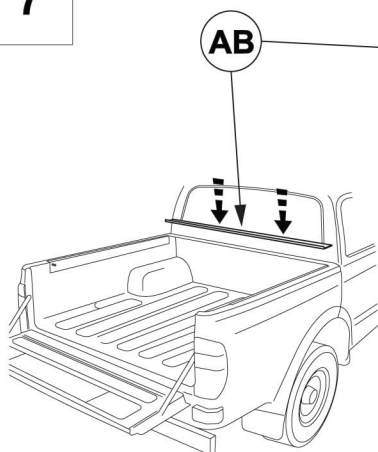

Modèle véhicule	λ
Isuzu D-Max Double & Extra Cab 2012	28mm
Volkswagen Amarok Double Cab 2010	27mm
Ford Ranger T6 Double & Extra Cab 2011	37.5mm
Mitsubishi L200 Double Cab Long Bed 2009	24mm
Nissan Navara NP300 2016 Double & King Cab	25mm



Ne pas installer si température ambiante inférieure à 15°C.
Appuyer sur le profil anti-pluie afin que l'adhésif adhère.
Laisser reposer 3h avant d'installer le tonneau cover.

8

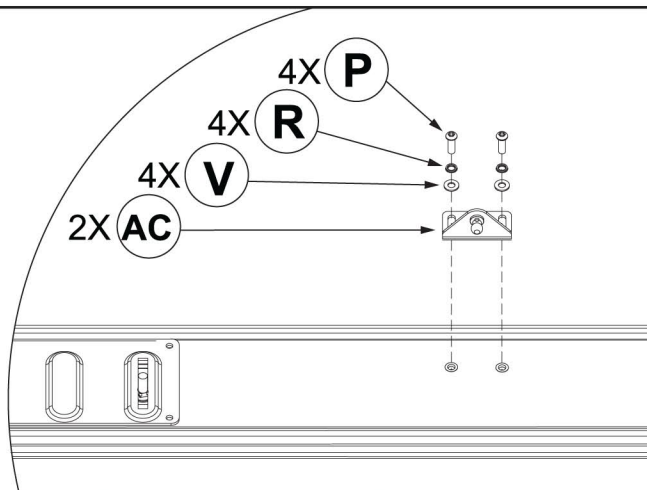
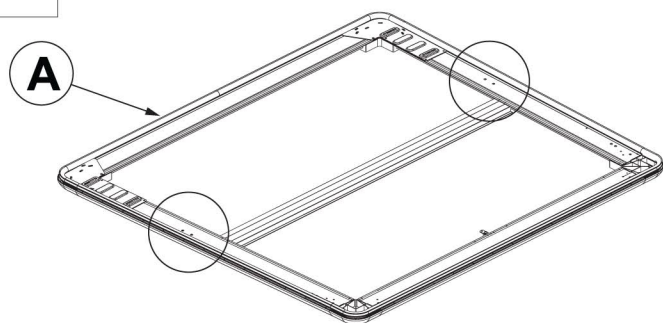

Kit de montage

Article

Revision

Date

Page

K408

Tonneau cover UpStone

1

01.07.2016

3 sur 7

9

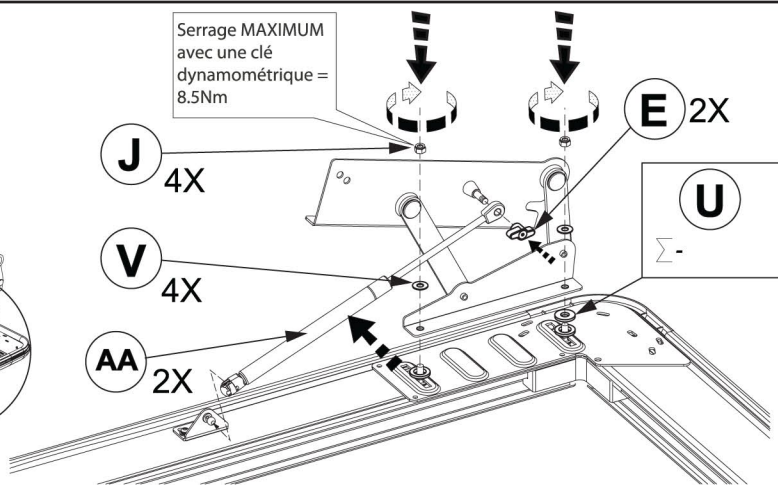
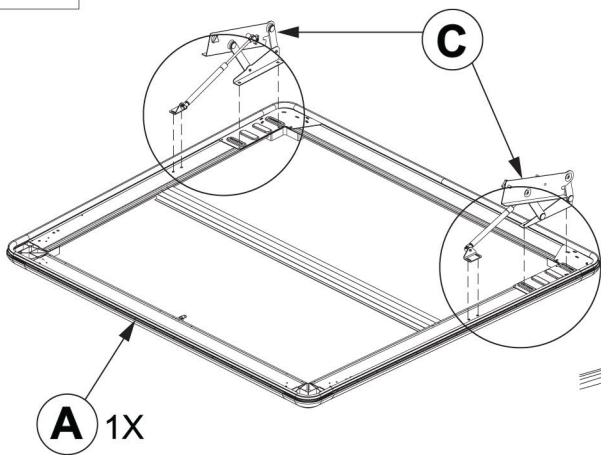

Modèle véhicule	□	⊖	Σ
Isuzu D-Max Double & Extra Cab 2012	26mm	29mm	-
Volkswagen Amarok Double Cab 2010	22mm	22mm	1 Qty
Ford Ranger T6 Double & Extra Cab 2011	16mm	16mm	2 Qty
Mitsubishi L200 Double Cab Long Bed 2009	30mm	30mm	-
Nissan Navara NP300 2016 Double & King Cab	25mm	25mm	-

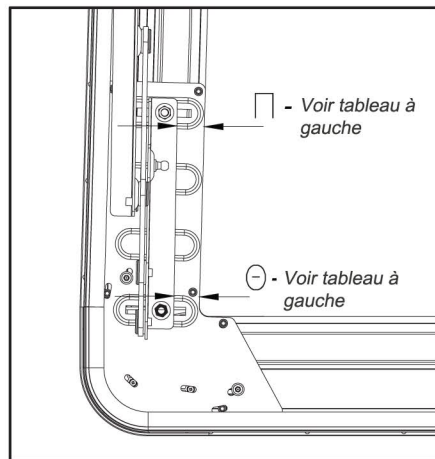

10

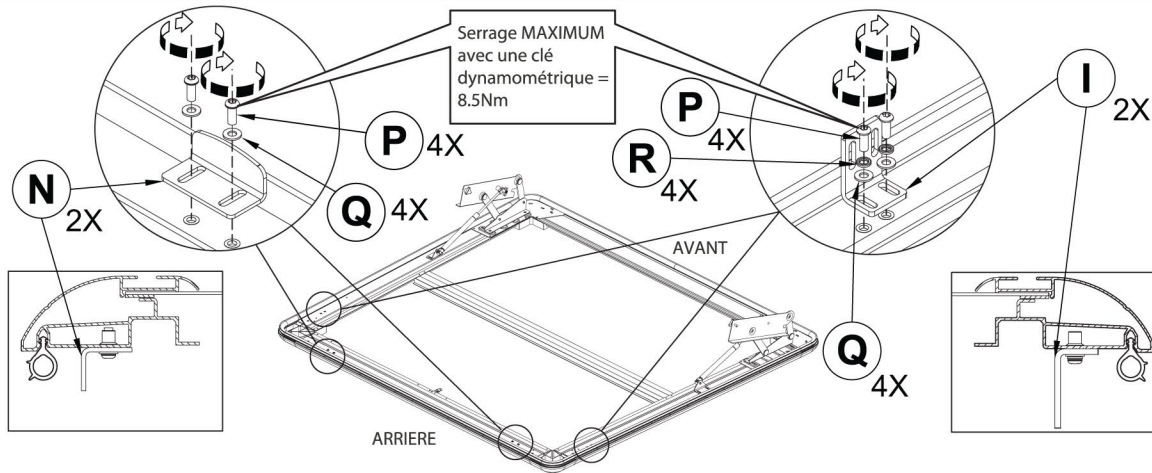

11

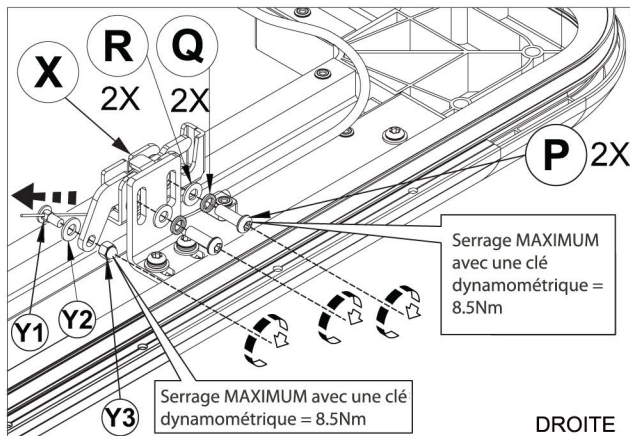
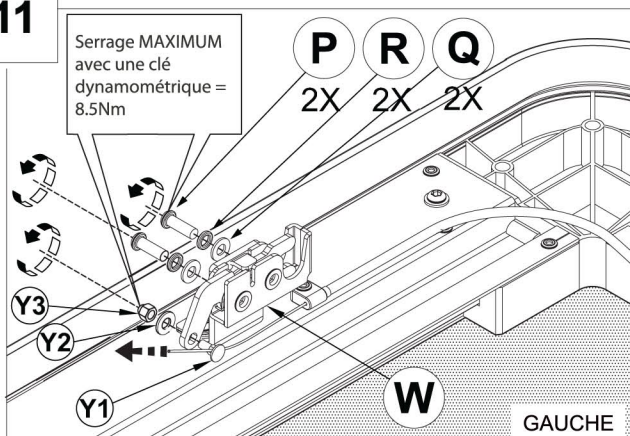

12

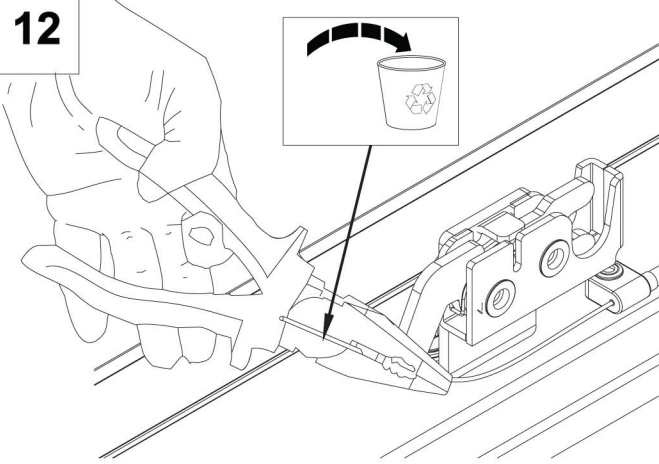

13

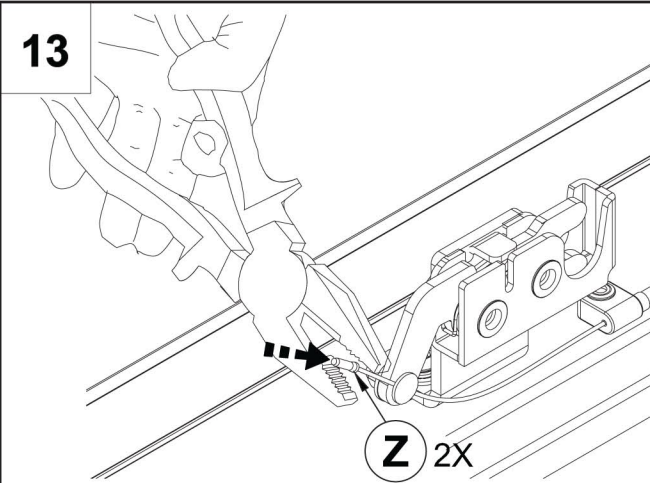

14

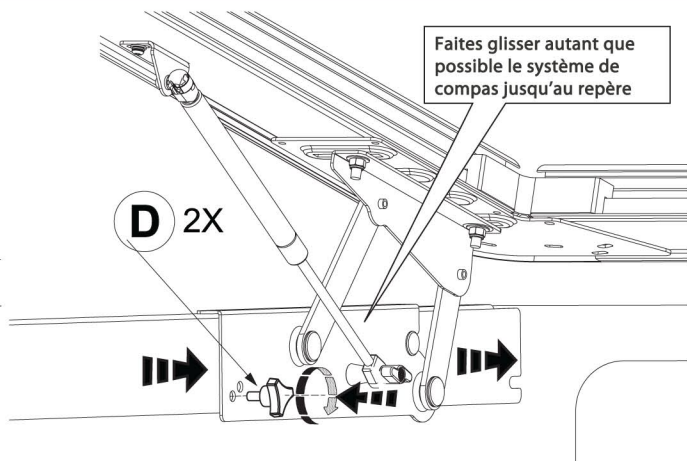
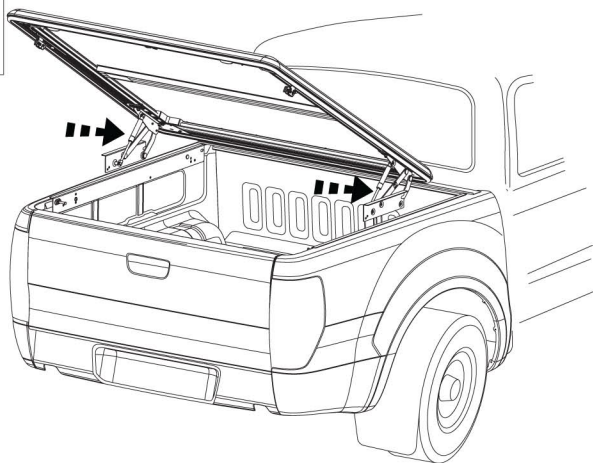

15

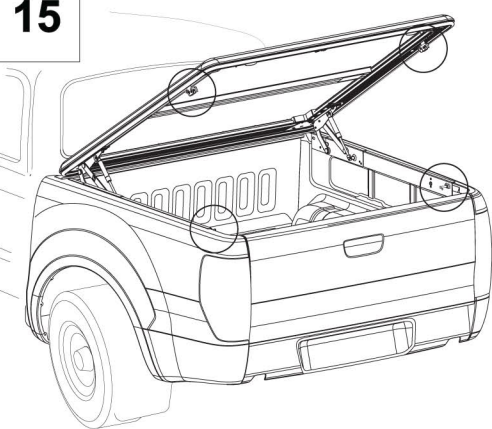

Serrage MAXIMUM avec une clé dynamométrique = 8.5Nm

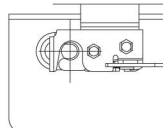
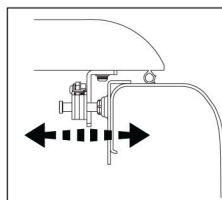
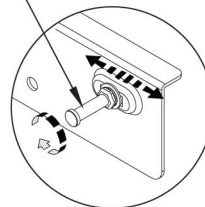
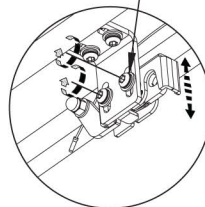
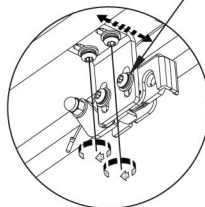

Aligner les gaches (femelle et mâle) de façon à ce que les gaches s'alignent parfaitement.

Ajuster la tension du câble.

Important : vérifier l'étanchéité du cover (joint).

16

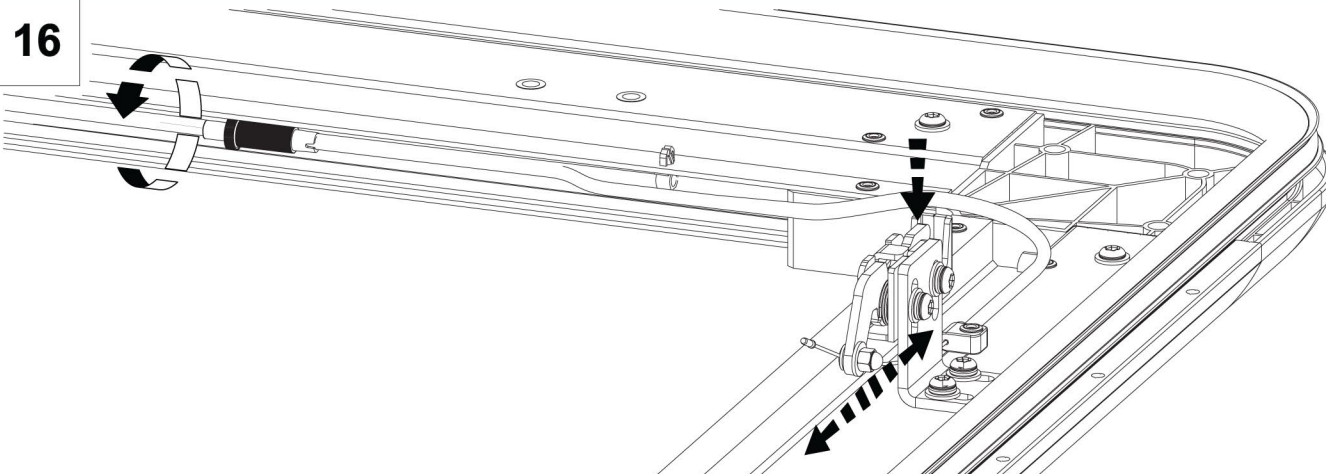

Kit de montage

Article

Revision

Date

Page

K408

Tonneau cover UpStone

1

01.07.2016

5 sur 7

17

Ne pas installer si température ambiante inférieure à 15°C.
Appuyer sur le profil anti-pluie afin que l'adhésif adhère.
Laisser reposer 3h avant d'installer le tonneau cover.

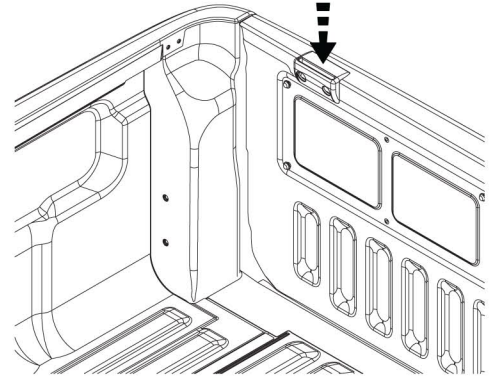
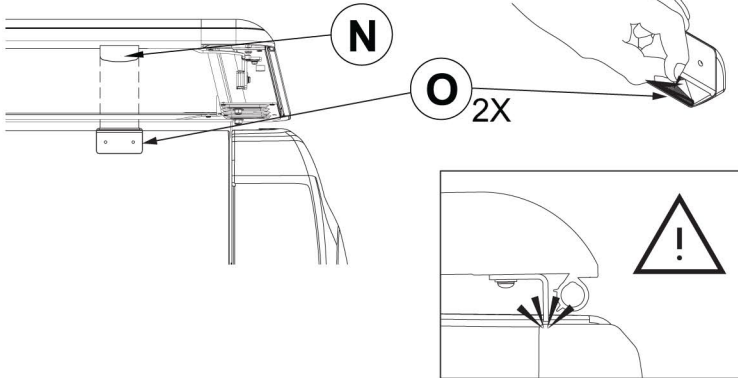

18

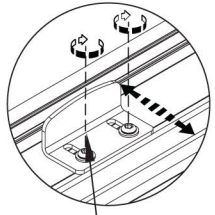
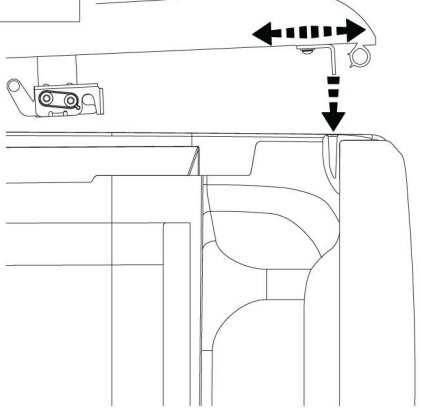

Serrage MAXIMUM avec une clé dynamométrique = 8.5Nm

19

OPTIONNEL

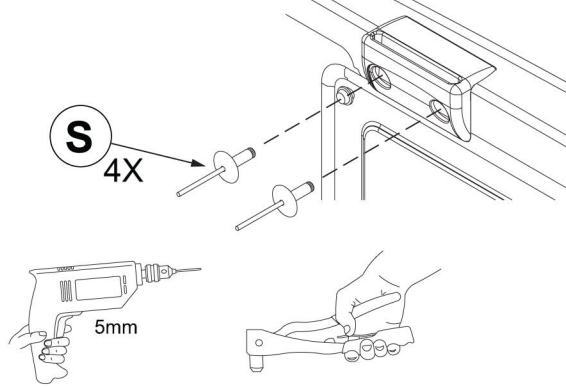

20



S'assurer que le vérin est parfaitement droit.
Ajuster le point d'attache sur la benne si nécessaire.

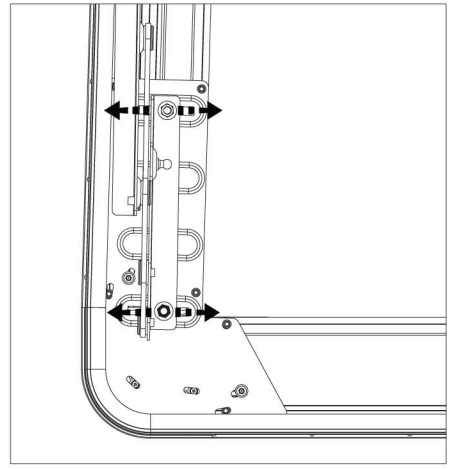
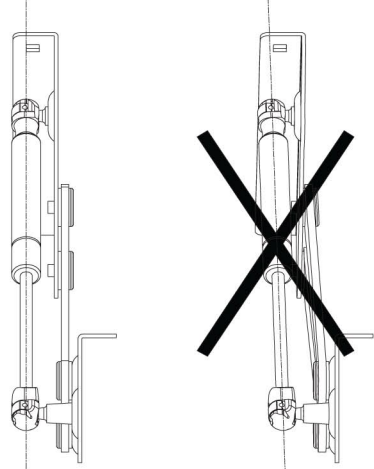

21

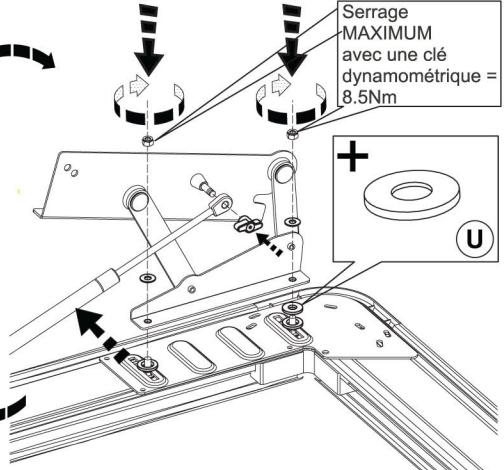
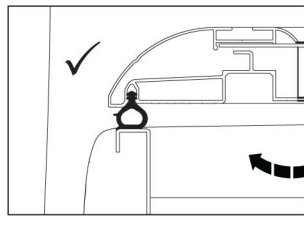
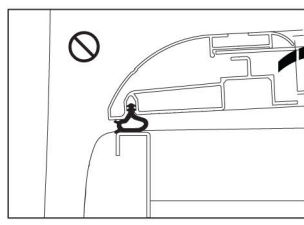
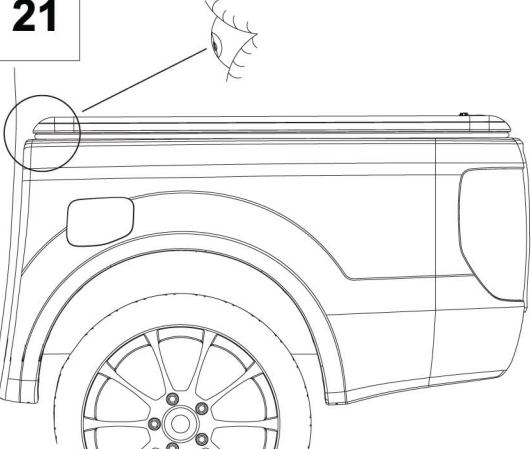

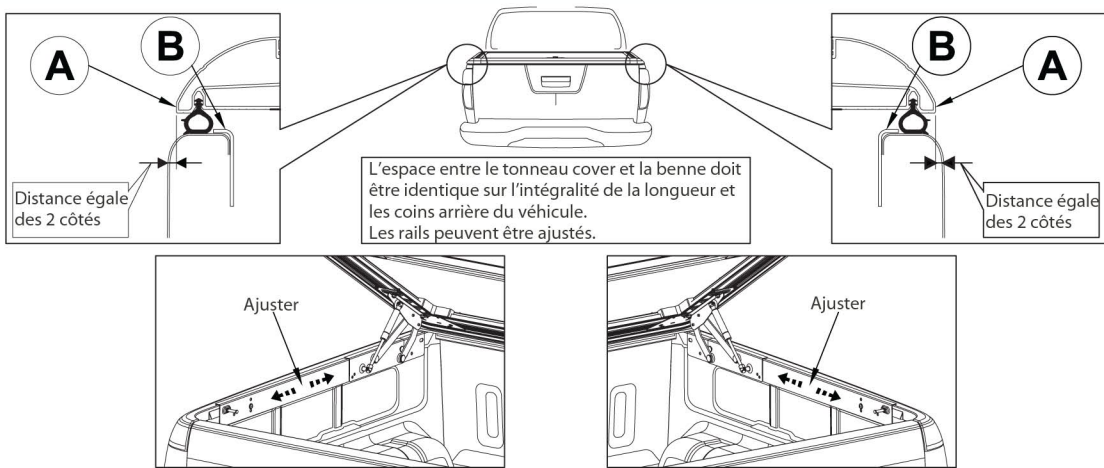

Une fois le montage terminé, nettoyez la benne de tous les débris et emballages.
Gardez cette notice de montage pour une utilisation future.



ATTENTION !

- Ne jamais enfermer dans la benne des personnes ou des animaux.
- Ne pas transporter des solvants ou produits chimiques ouverts.
- Ne pas marcher sur le tonneau cover ou y placer des objets lourds.
- Ne pas soulever le cover avec un chargement.
- Ne pas rouler avec le tonneau cover ouvert.
- Eviter tout contact d'huile, solvant ou produit chimique avec le cover.
- Nettoyer le cover avec un détergent doux et de l'eau.