

RU ИНСТРУКЦИЯ ПО УСТАНОВКЕ КОМПЛЕКТА ЗАЩИТ**GB** SKID PLATE INSTALLATION MANUAL**DE** INSTALLATIONSEINLEITUNG VON UNTERBODENSCHUTZ**Skid plate for:****Nissan Navara D40 V-2,5d; 3,0d (2005-2015);****Nissan Navara D23 V-2,5d (2015-)****(Aluminium) 333.4164.1/6; 333.4165.1/6; 333.4166.1/6; 333.4167.1/6**



РАСПОЛОЖЕНИЕ
LOCATION/POSITION ARROW
ANORDNUNG/
POSITIONSRICHTUNG



ДВИЖЕНИЕ
MOVEMENT ARROW
BEWEGUNGSRICHTUNG



ПОВОРОТ
SCREW ARROW
DREHUNGSRICHTUNG

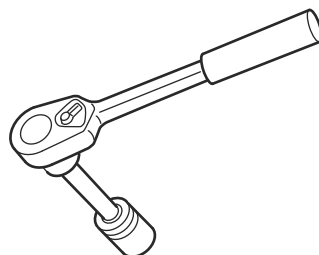
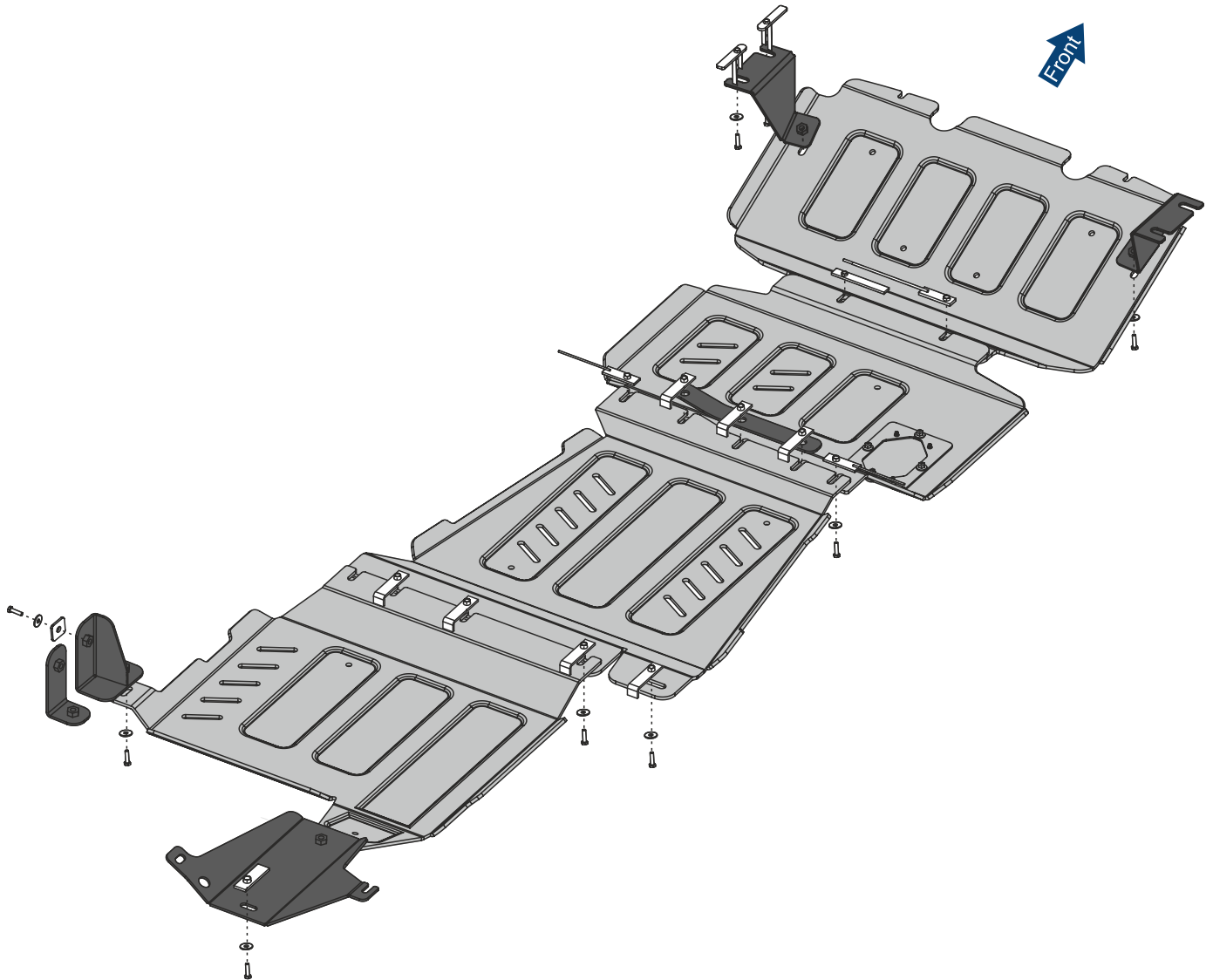

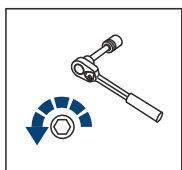

RU Штатный крепеж
GB Regular fasteners
DE Originale montageteile

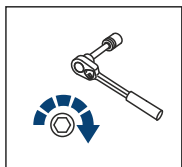

RU Штатный крепеж
GB Regular fasteners
DE Originale montageteile

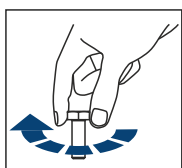

RU Вкрутить на несколько оборотов
GB Screw a several turns
DE Für wenigen Umdrehungen befestigen

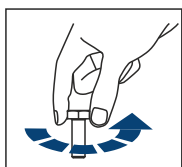

RU Выкрутить на несколько оборотов
GB Loosen bolts
DE Bolzen lockern

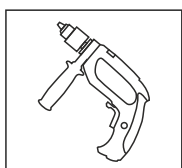

RU Дрель
GB Drill
DE Bohrer

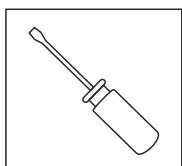

RU Отвертка
GB Screwdriver
DE Schraubenzieher

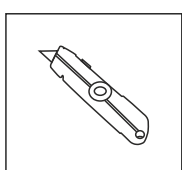

RU Канцелярский нож
GB Office Knife
DE Büromesser

A			1x	
B	<p>M8x35</p>	4x	C <p>M10x30</p>	5x
D	<p>M10x40</p>	2x	E <p>M10x60</p>	5x
F	<p>M10x80</p>	3x	G <p>M12-1,25x30</p>	2x
H	<p>M10x80</p>	7x	I <p>M10</p>	2x
J	<p>M10x65/20</p>	1x	K <p>M8</p>	1x

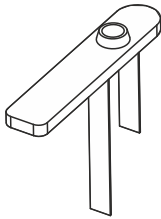
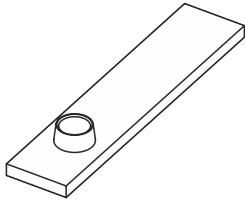
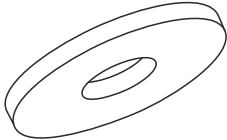
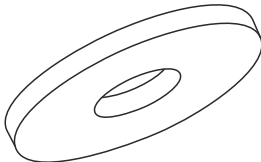
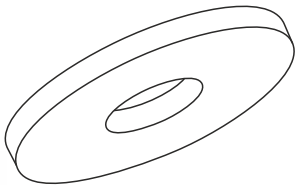
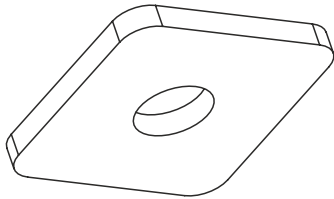
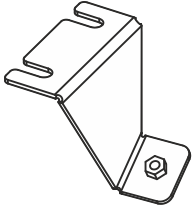
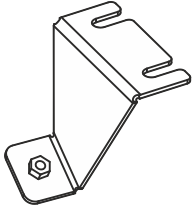
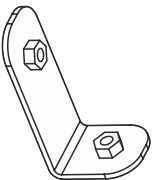
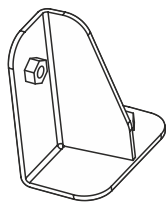
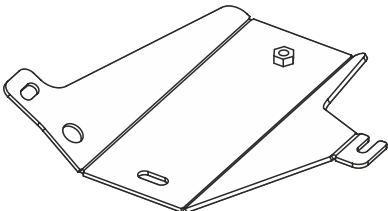
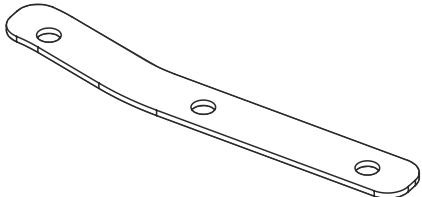
L			M
M8x70/20	2x	M8x100/20	1x
N			O
∅ 8	4x	∅ 10	15x
P			Q
∅ 12	2x	∅ 10	1x
R			S
	1x		1x
T			U
	1x		1x
V			W
	1x		1x

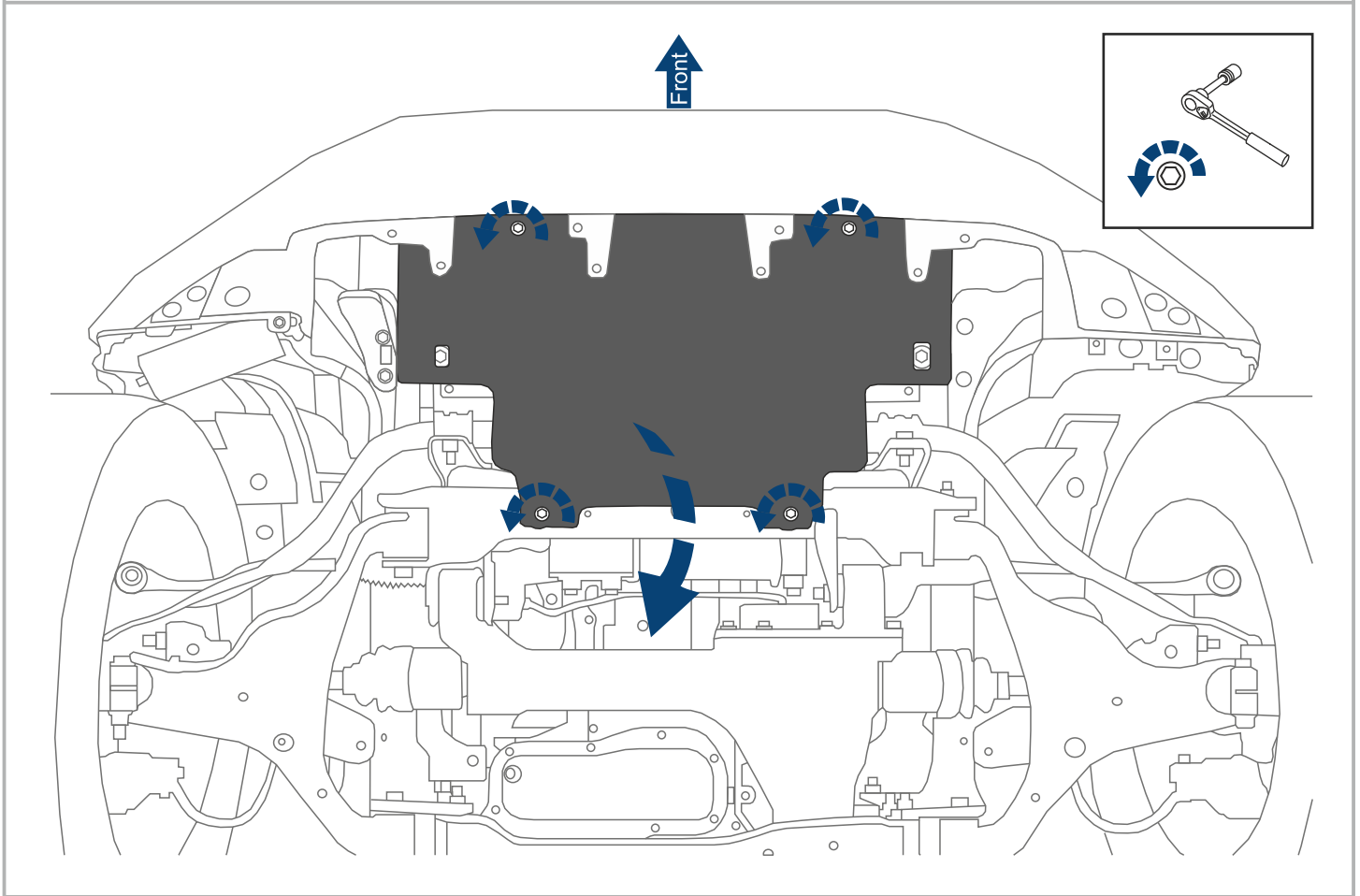
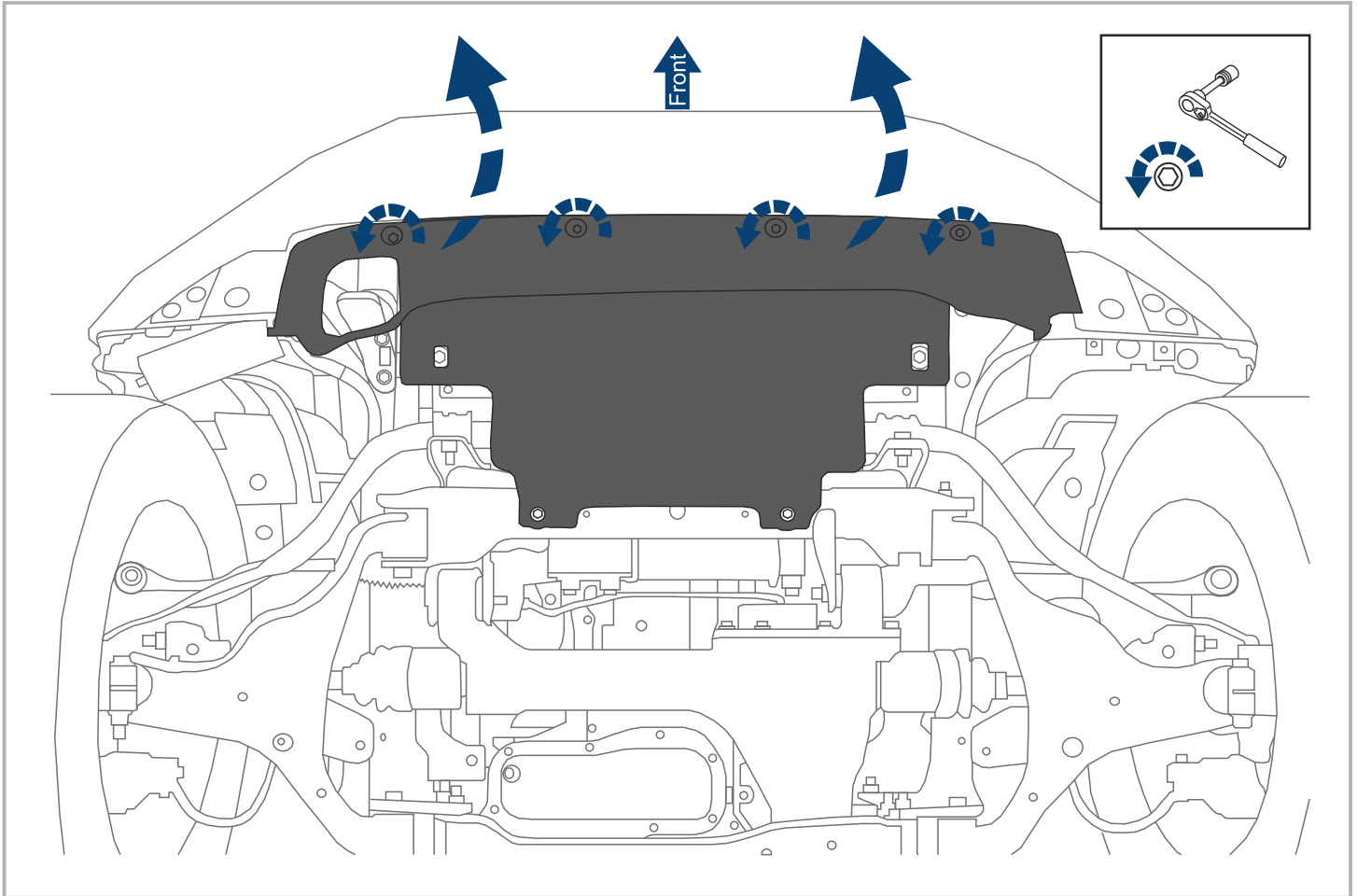

Navara D40

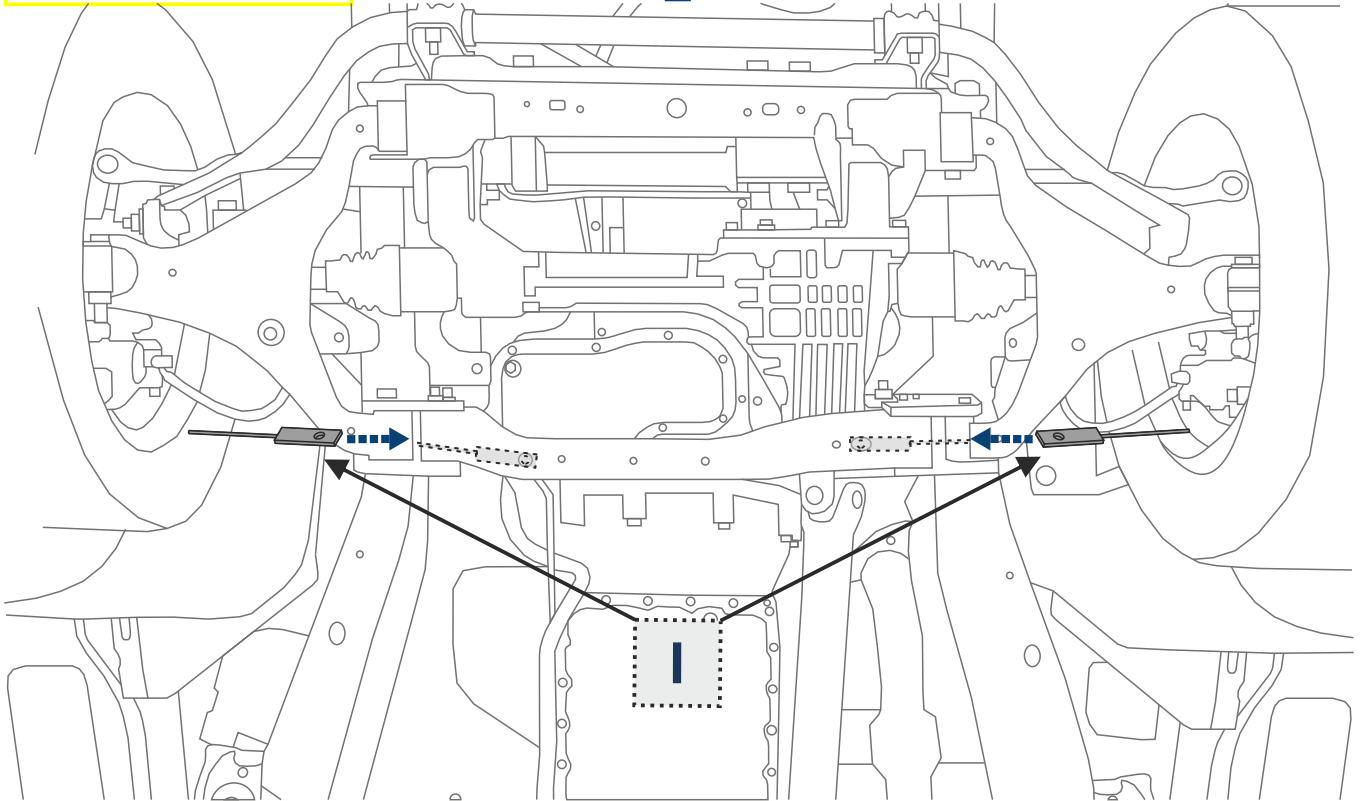

Navara D23/D40

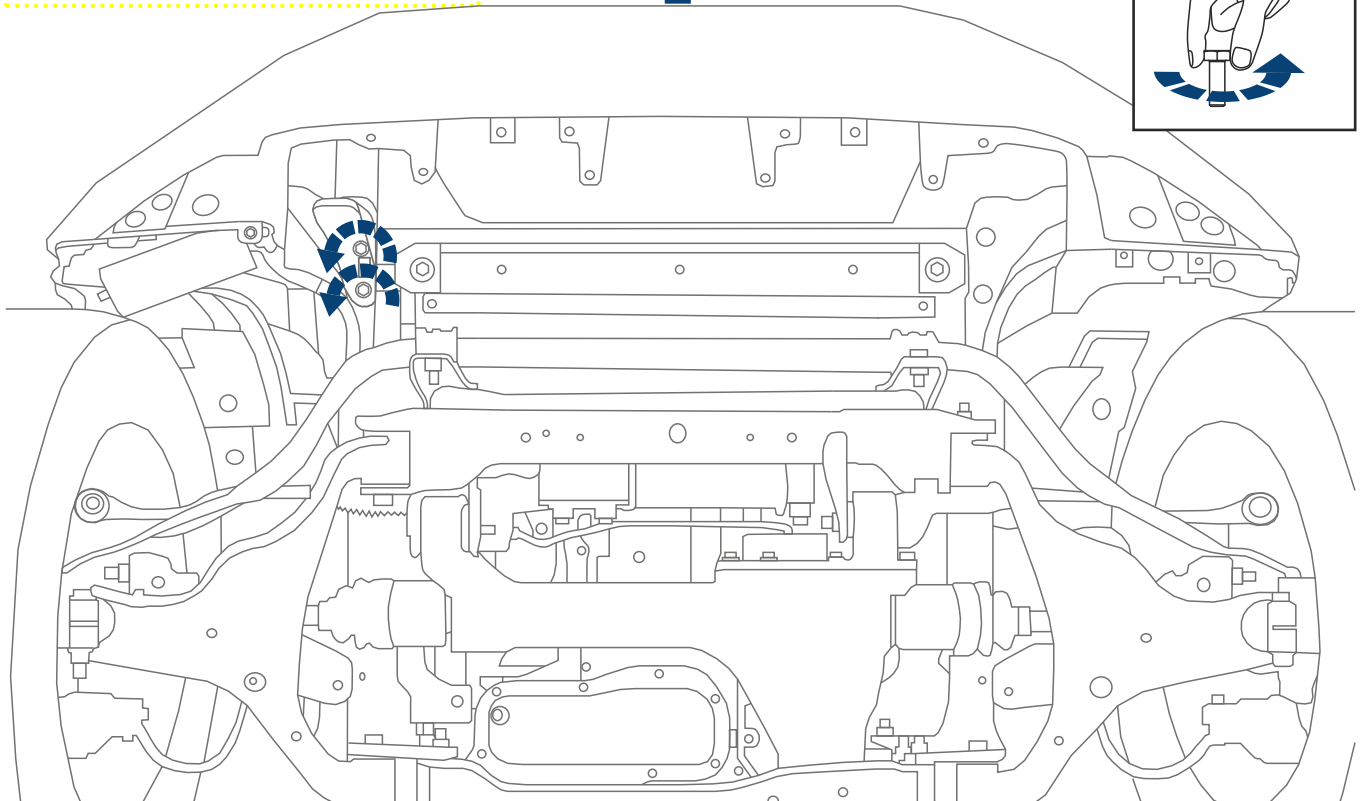
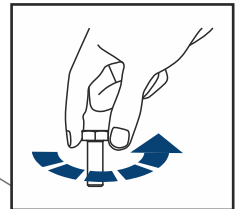

Navara D23/D40

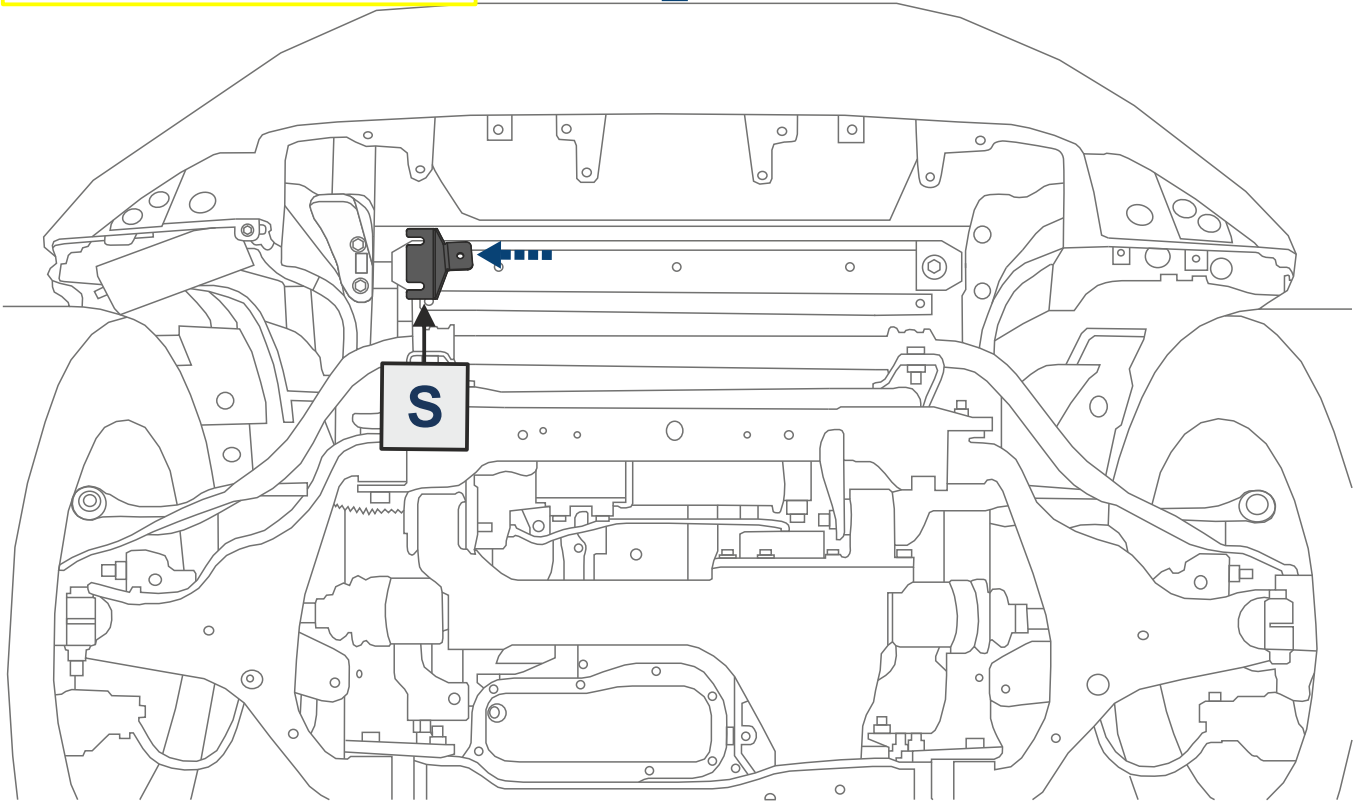

Navara D23/D40

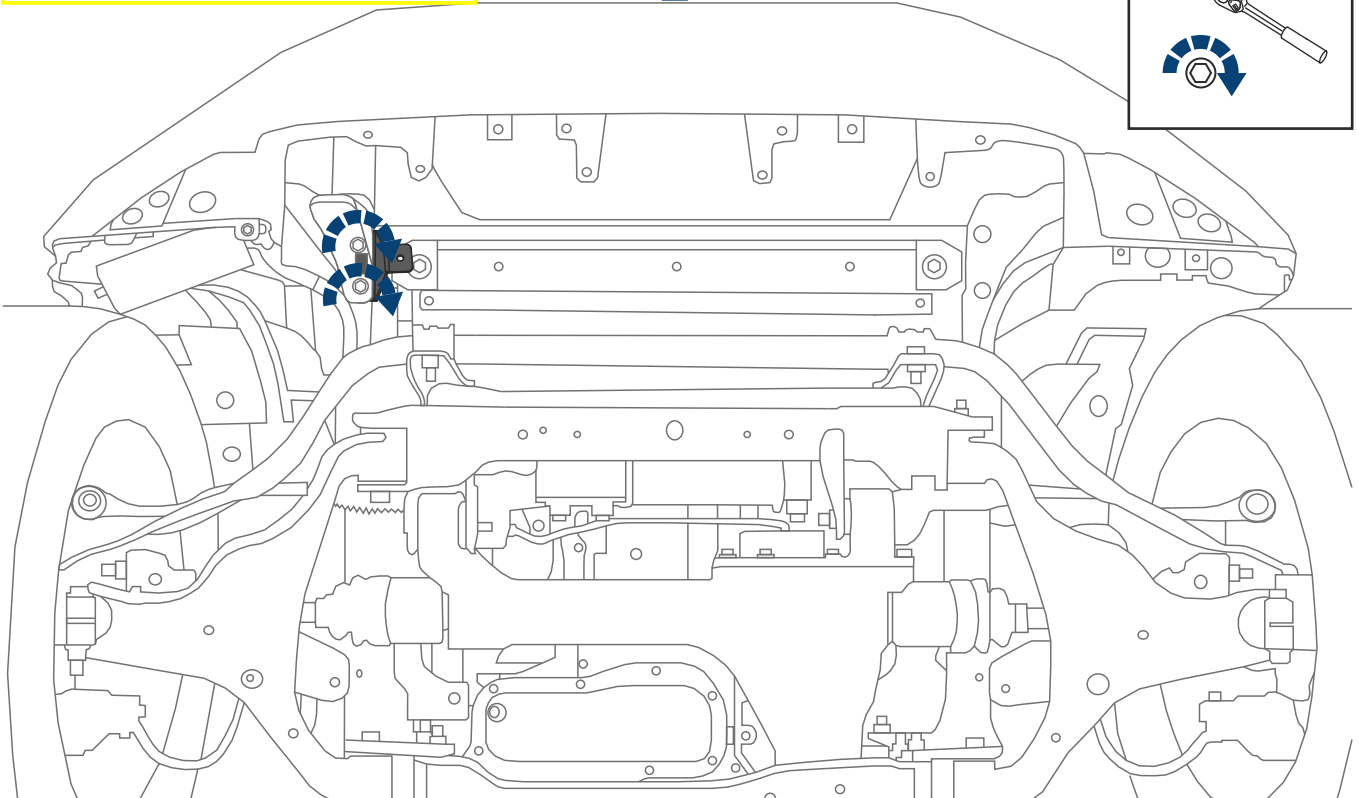
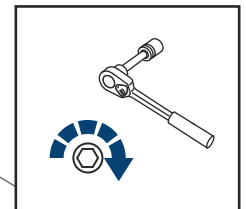

Navara D23

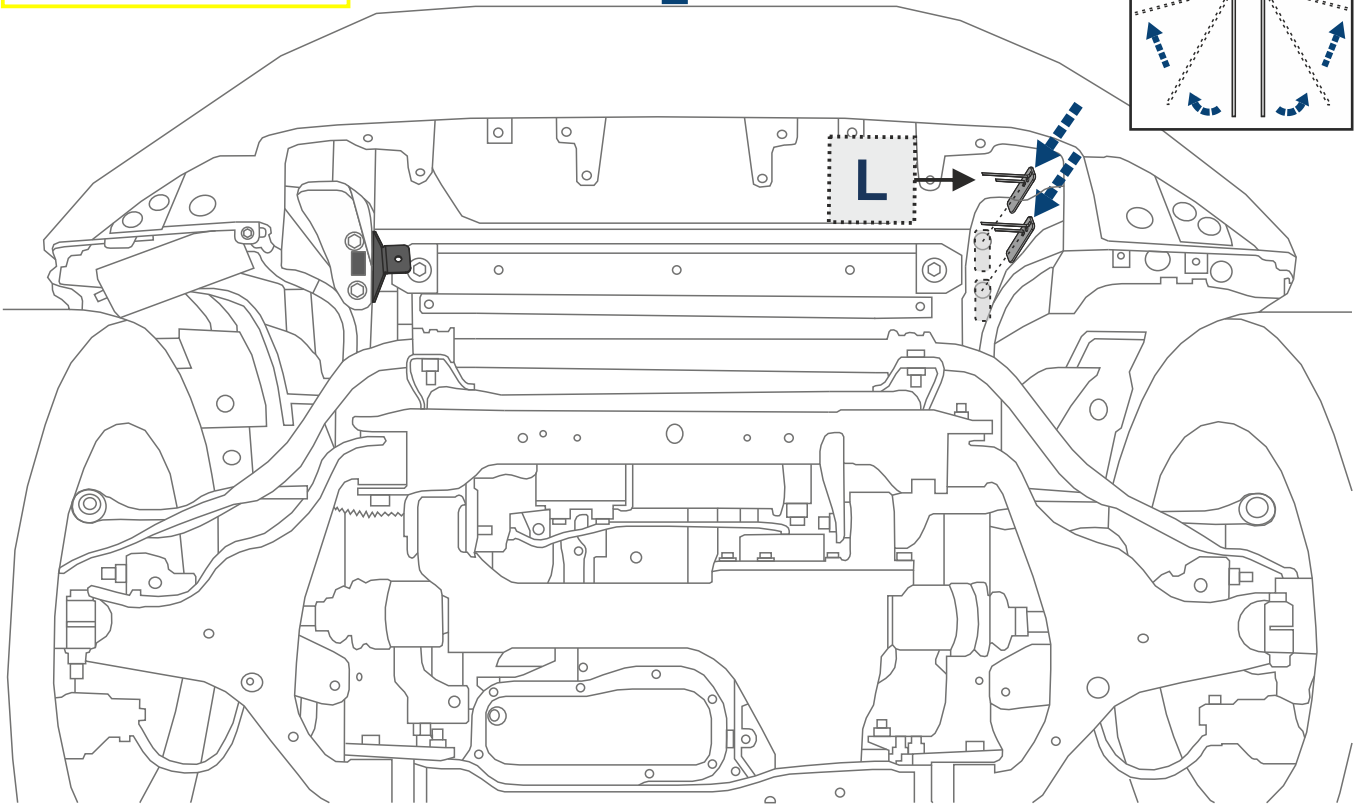
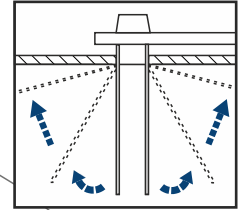

Navara D23

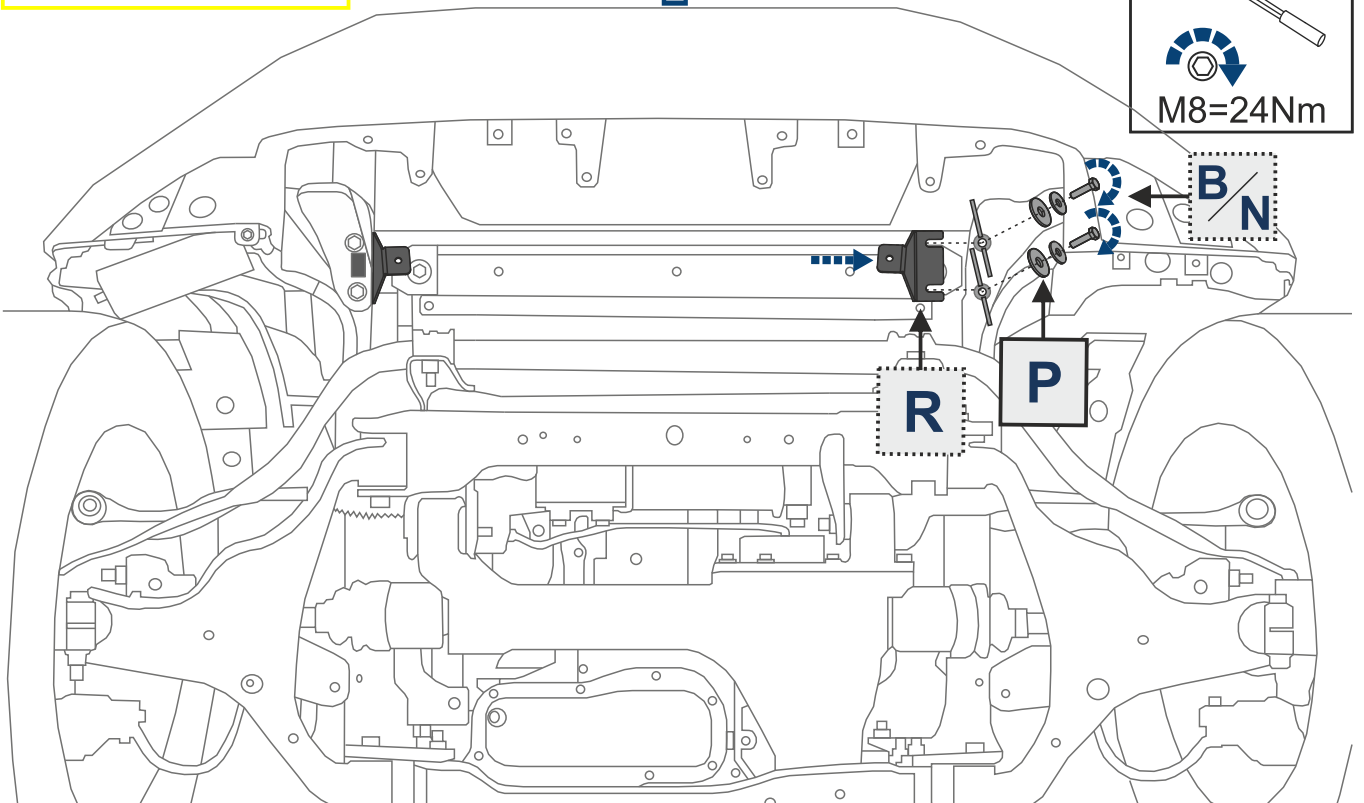
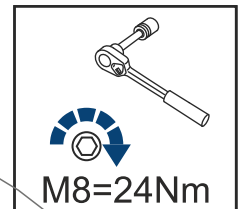

Navara D40

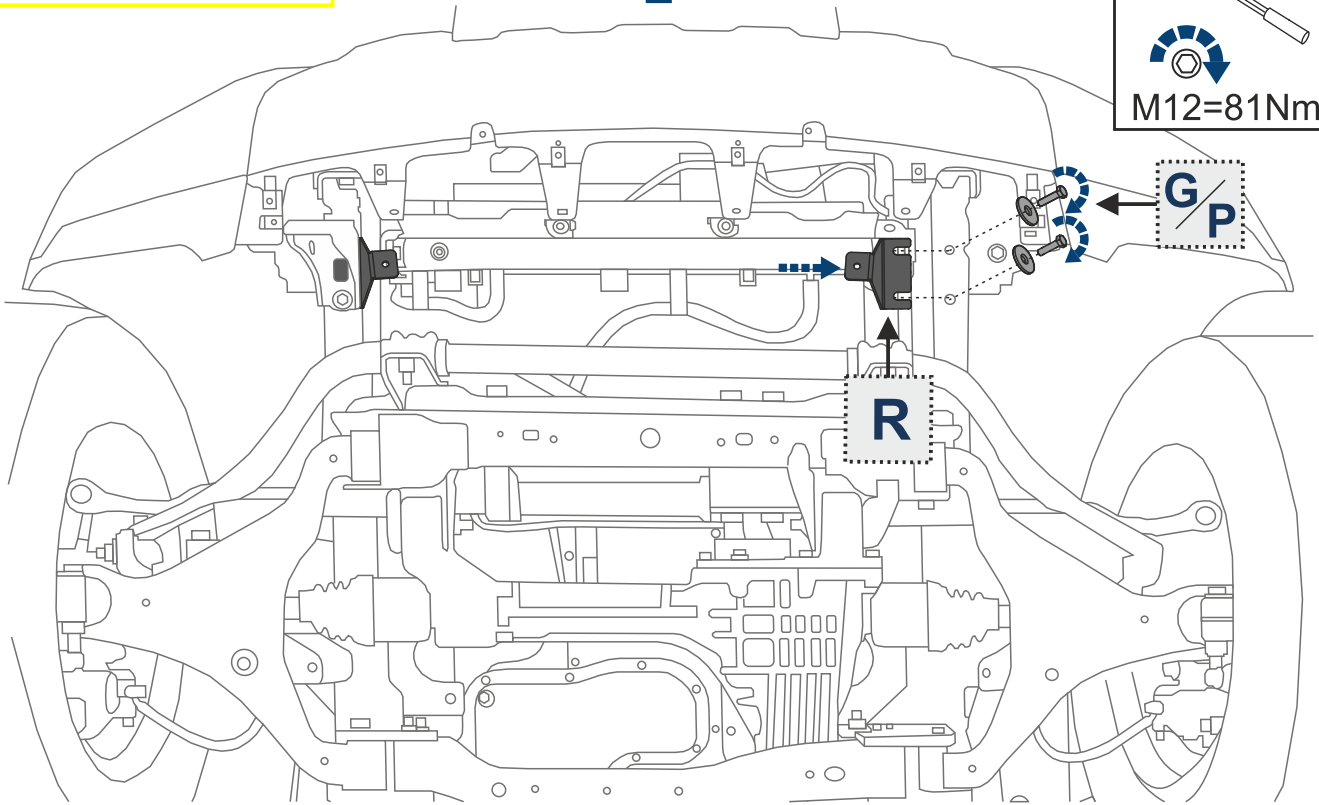
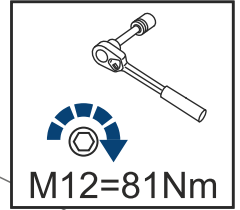

Navara D23

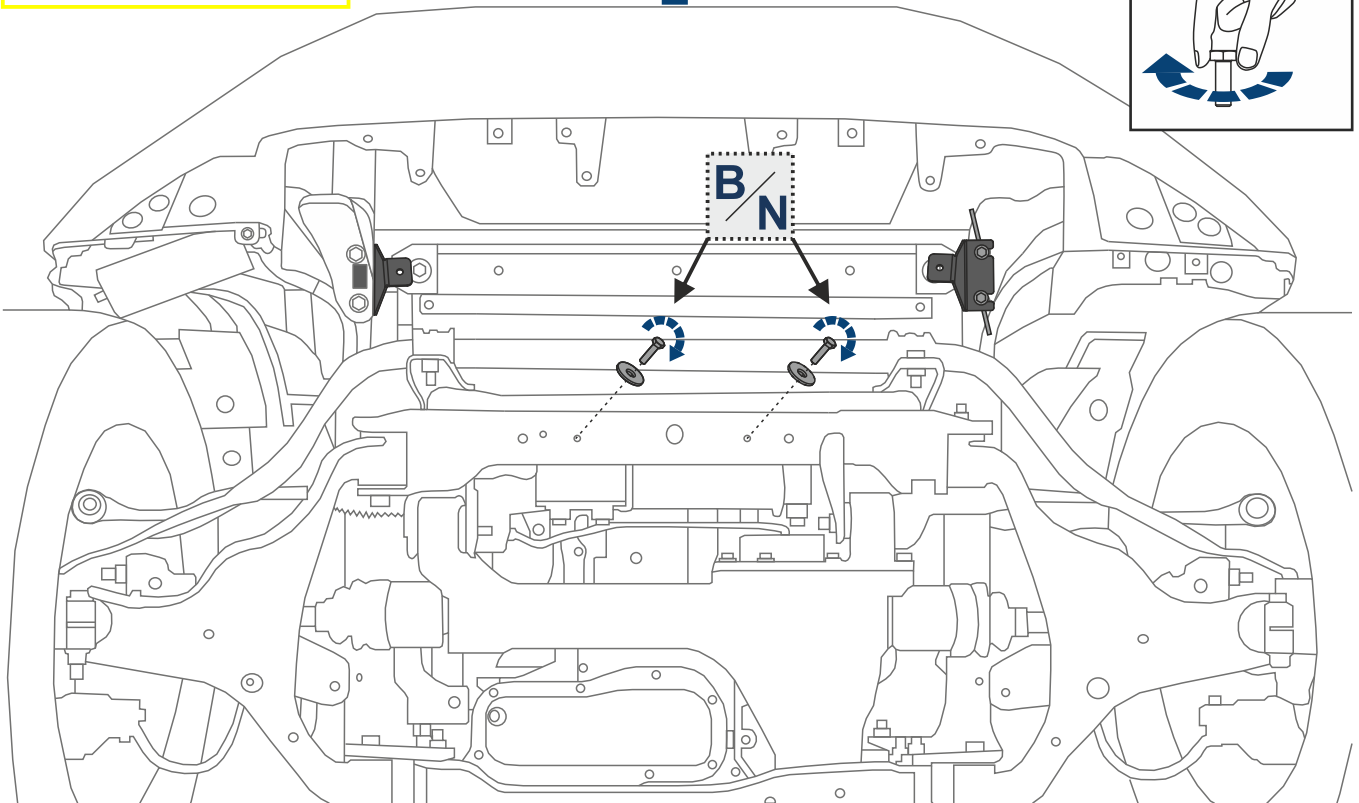
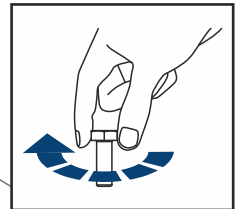

Navara D40

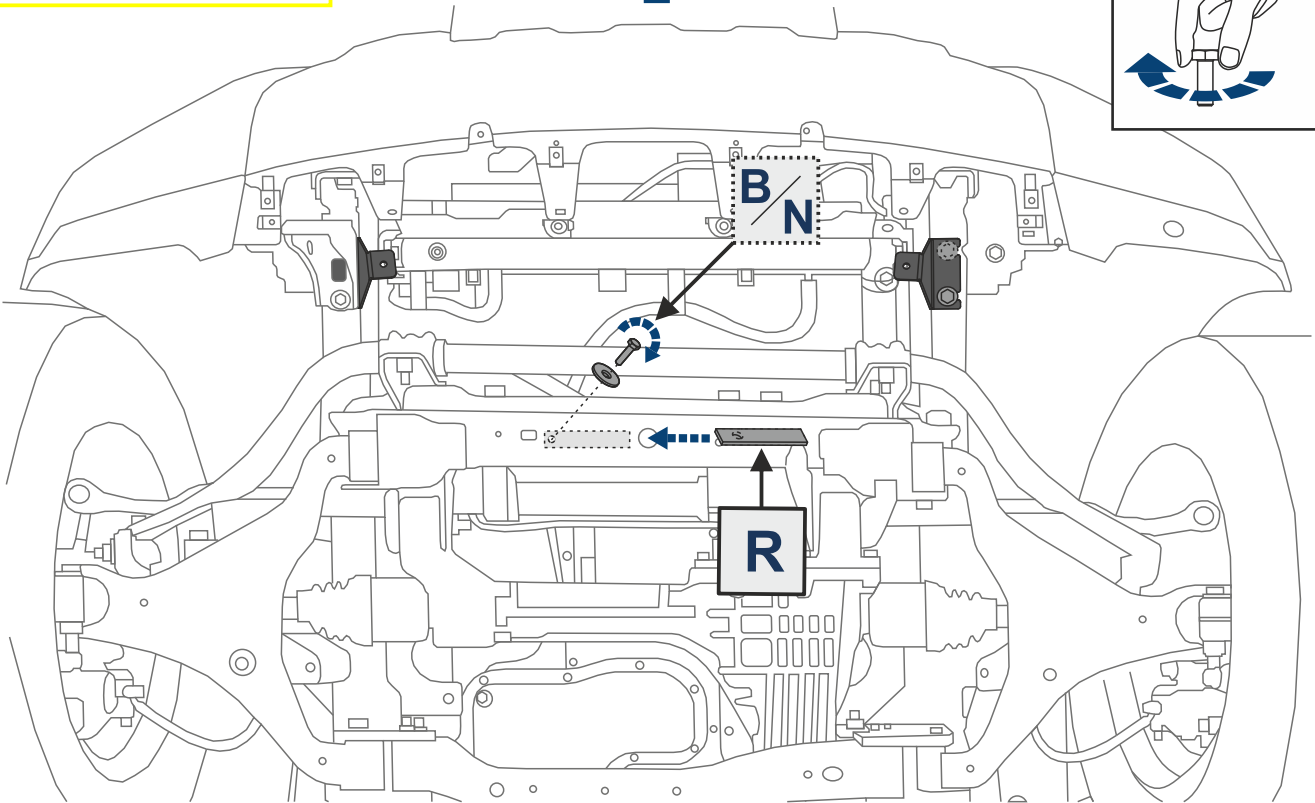
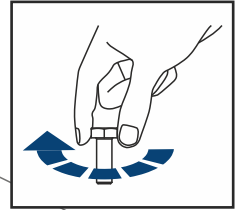

Navara D40

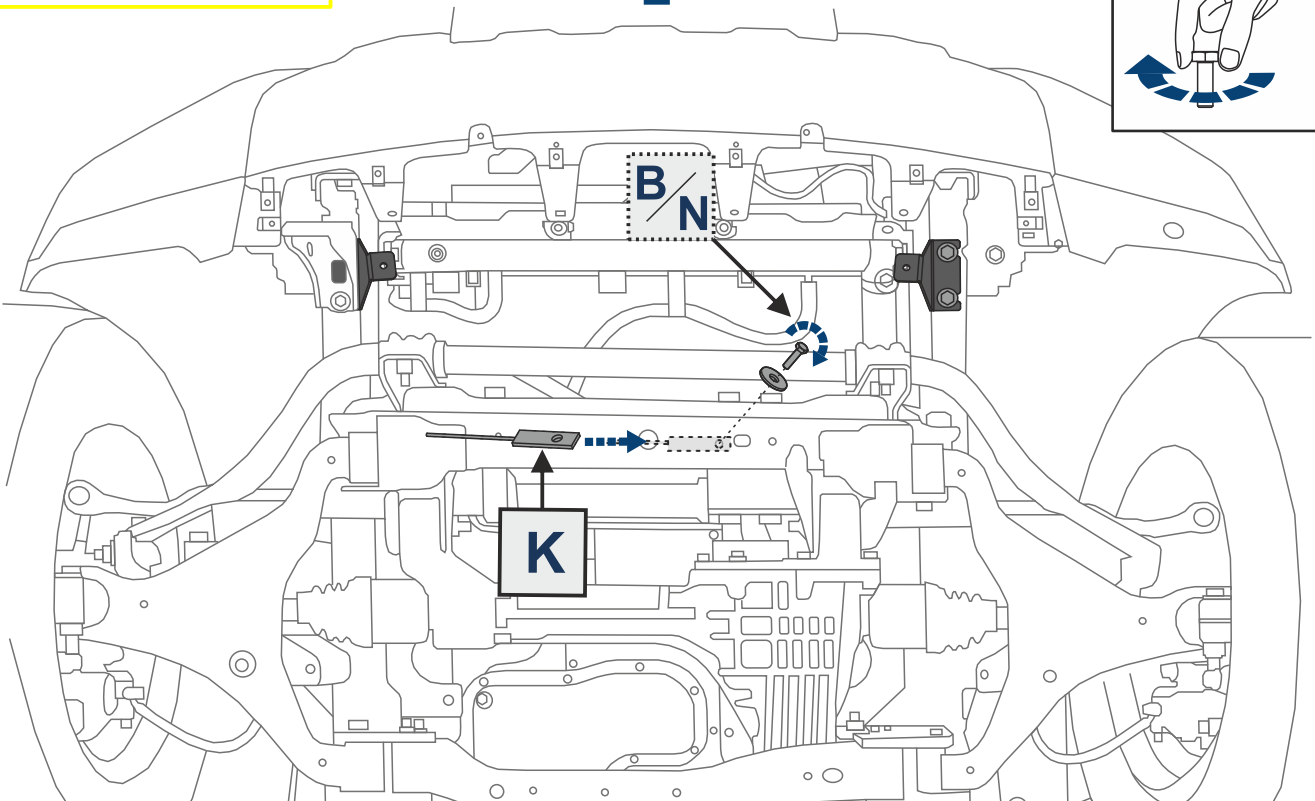
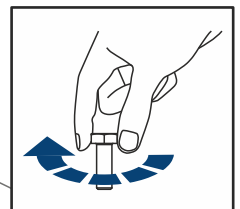

Navara D23/D40

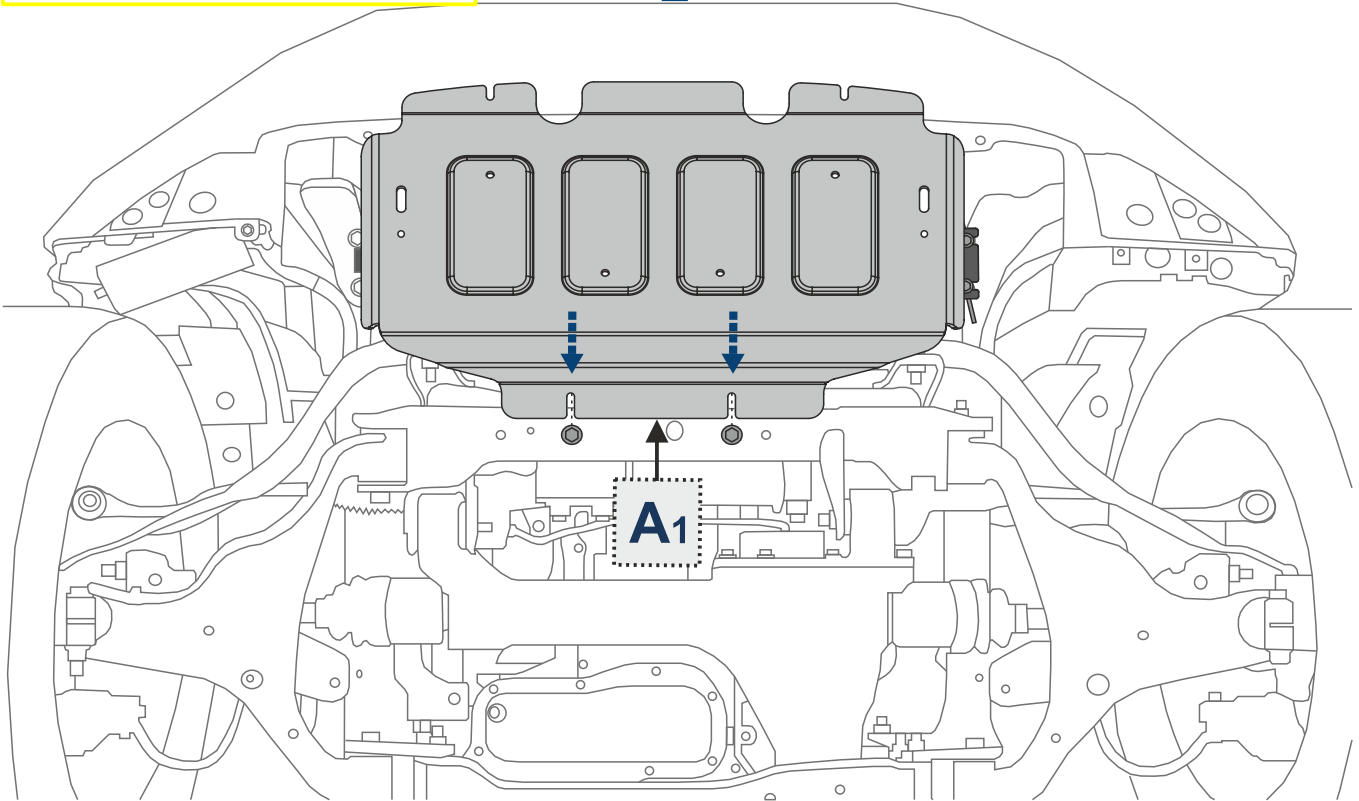

Navara D23/D40

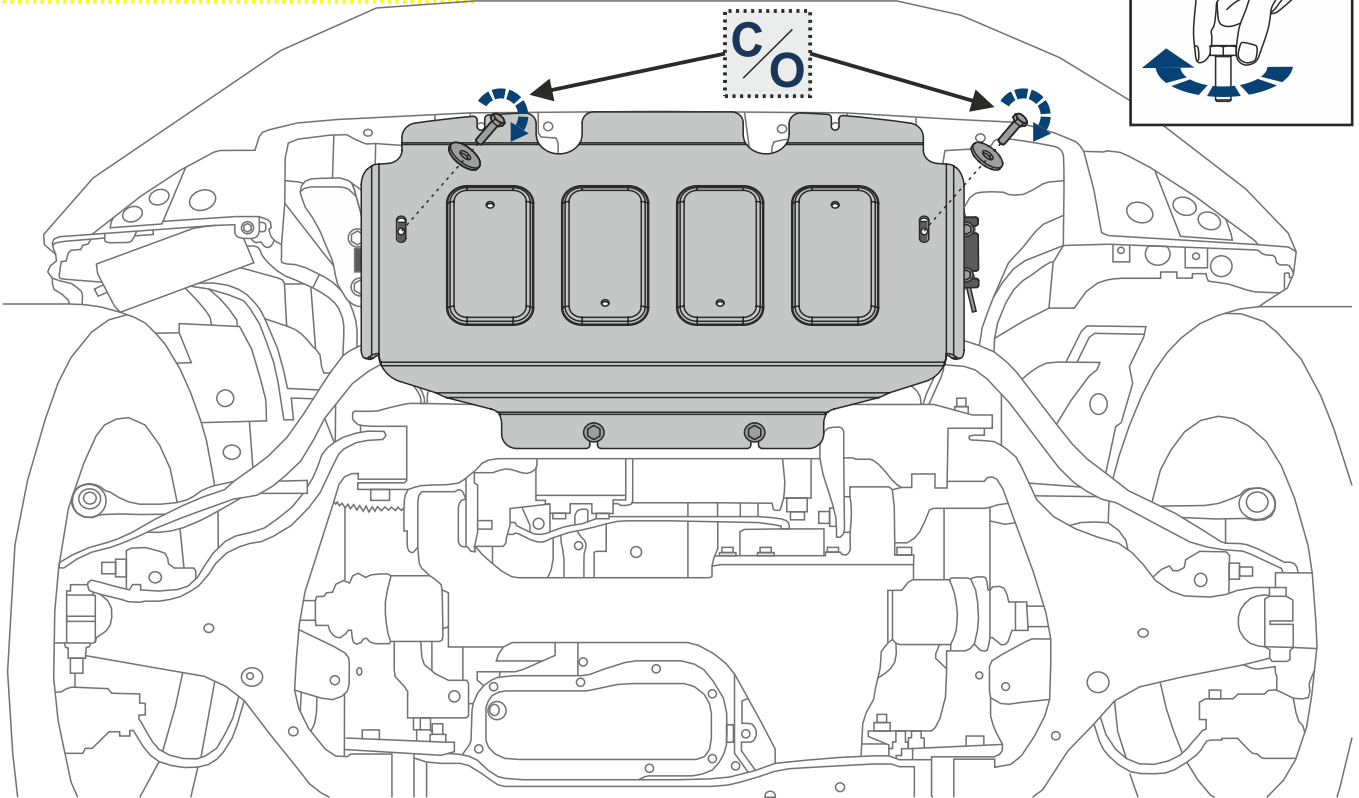

Navara D23

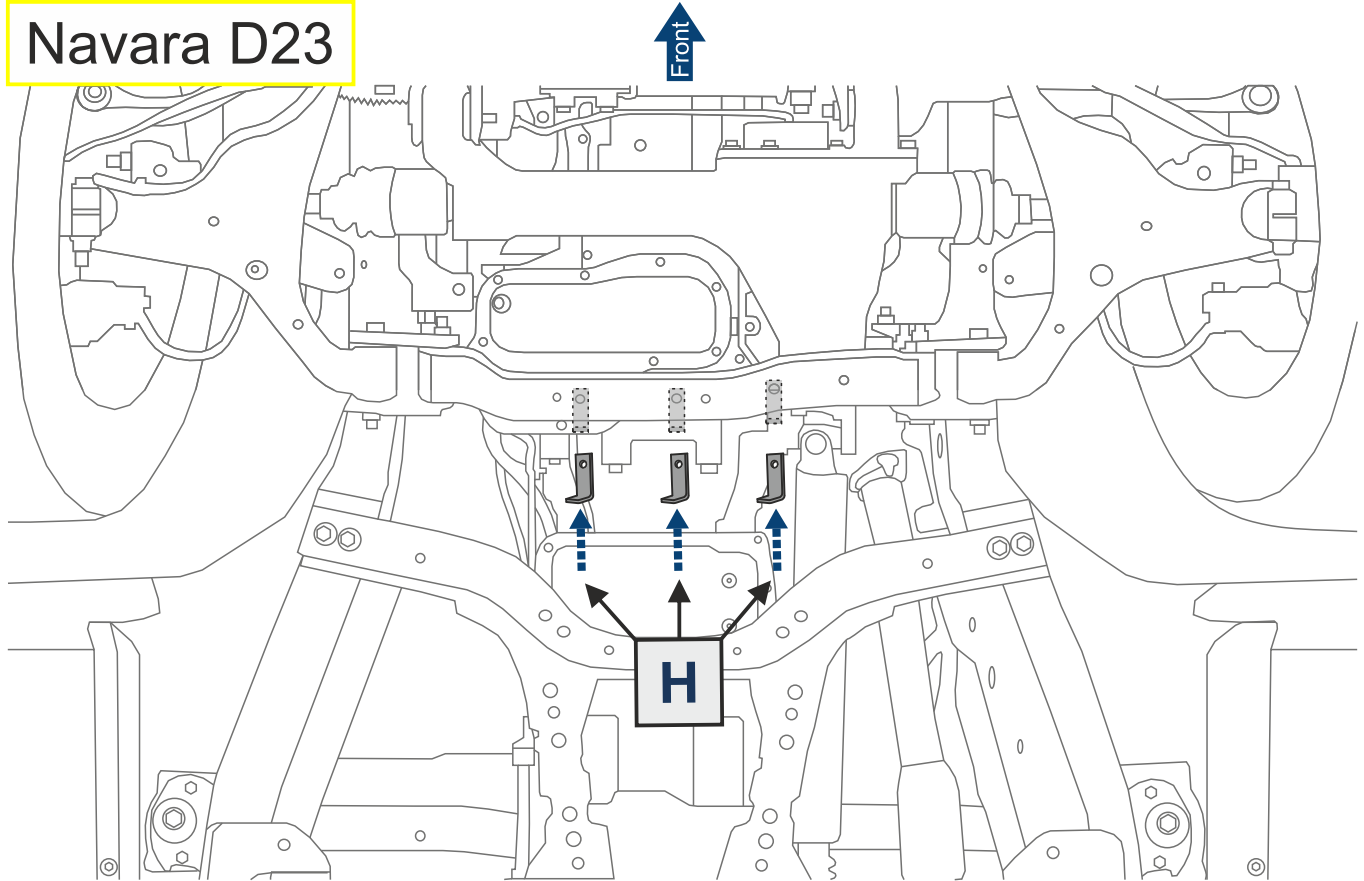

Navara D23

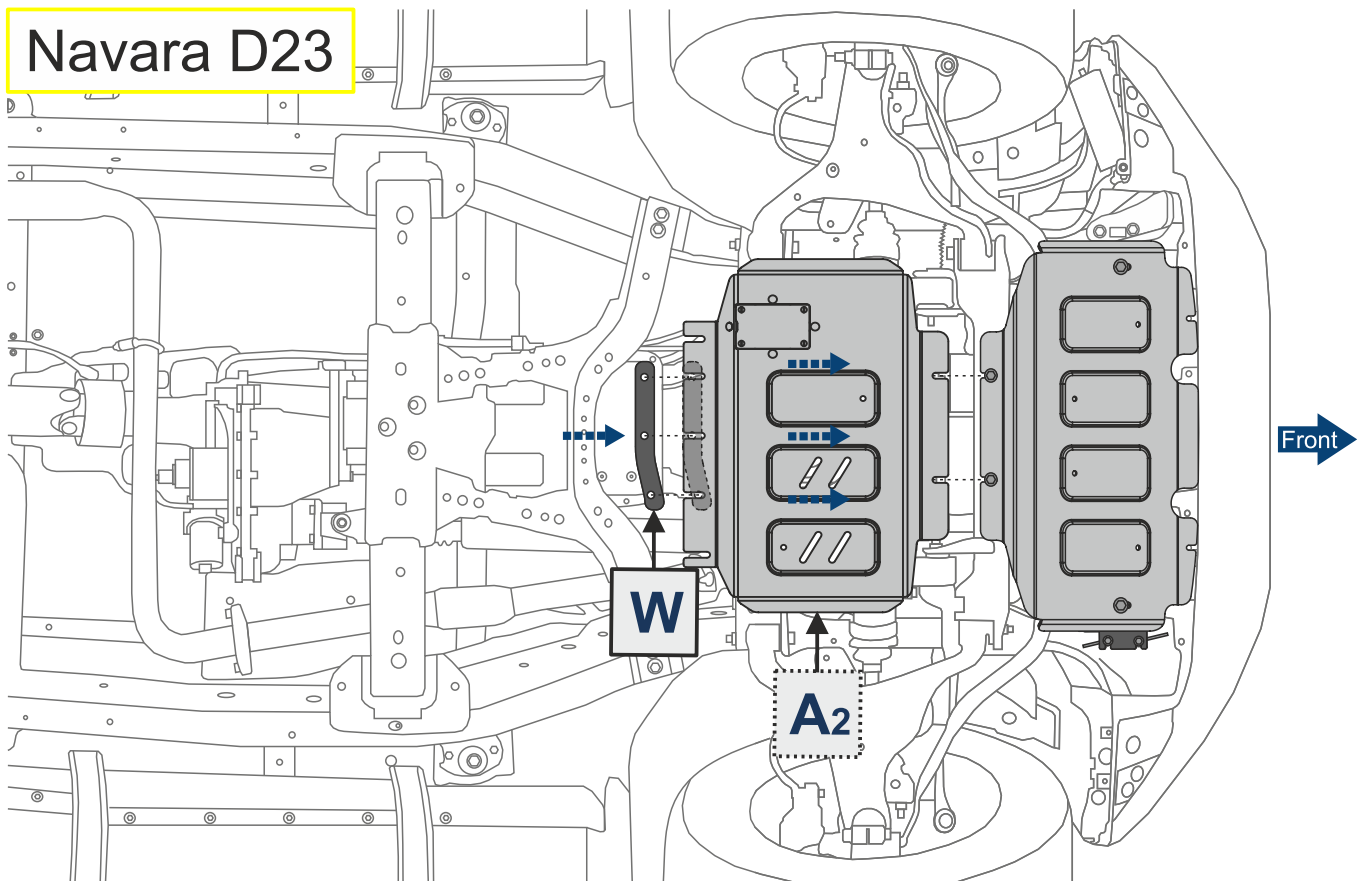

Navara D23

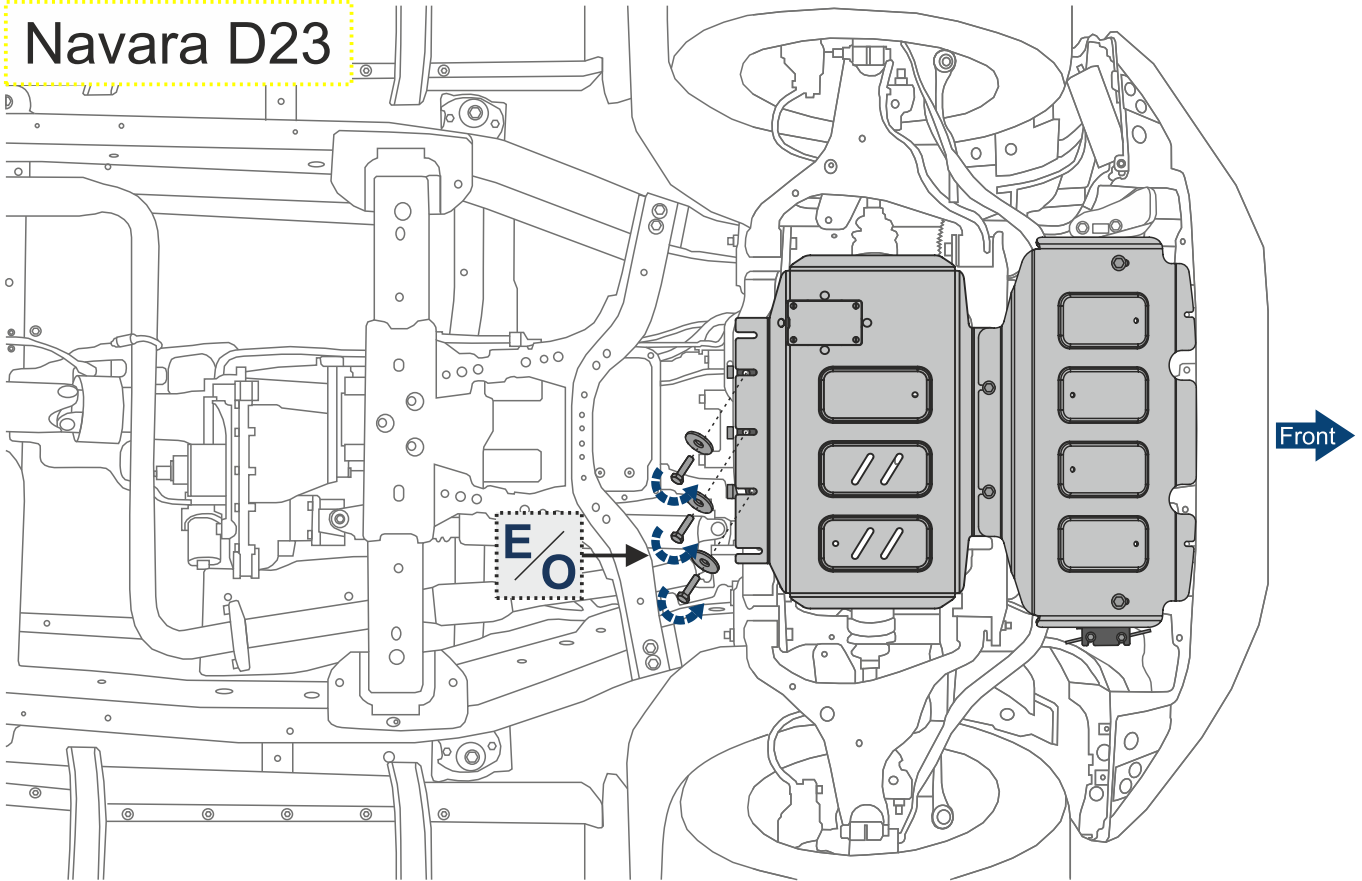

Navara D40

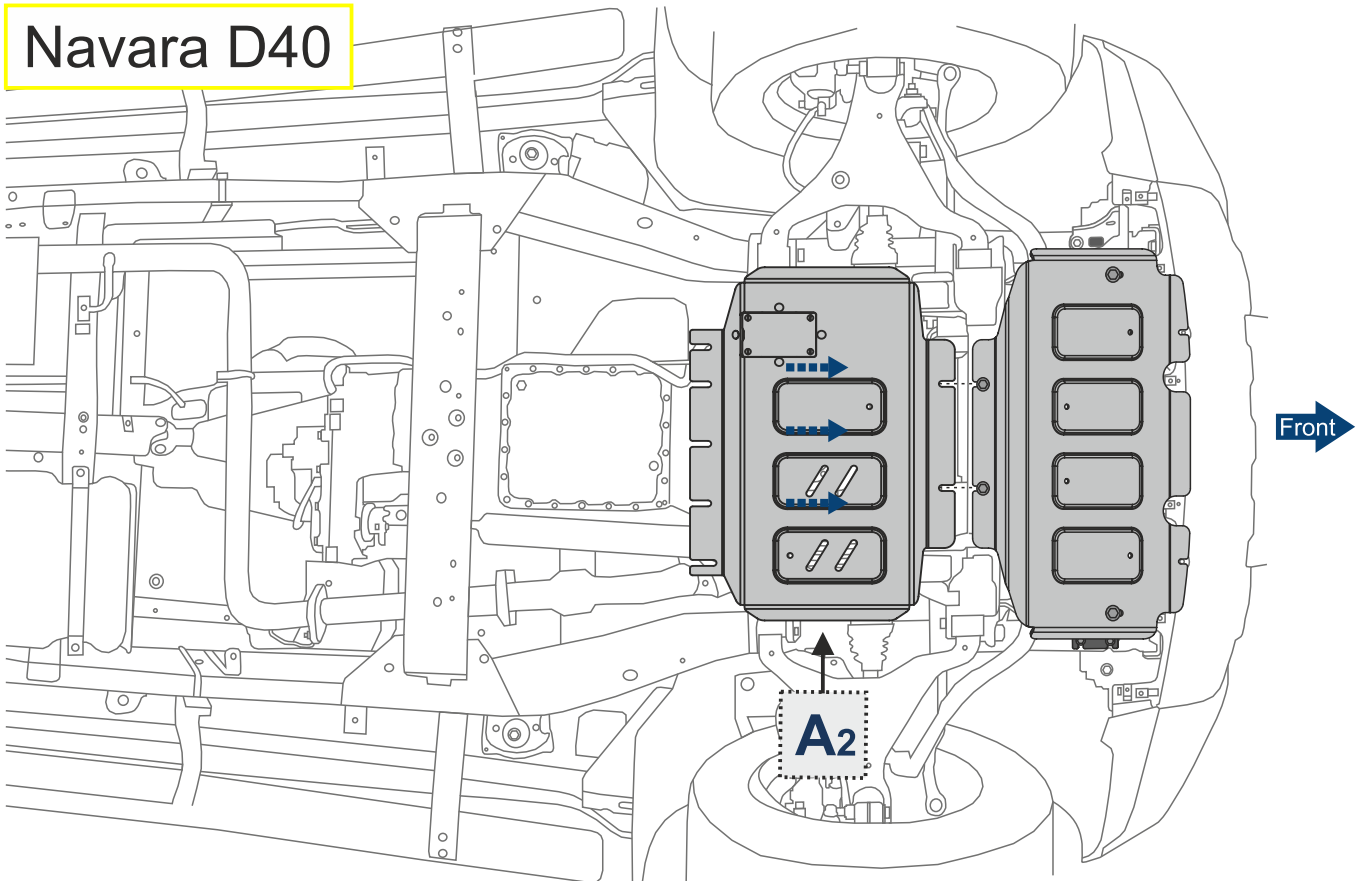

Navara D40

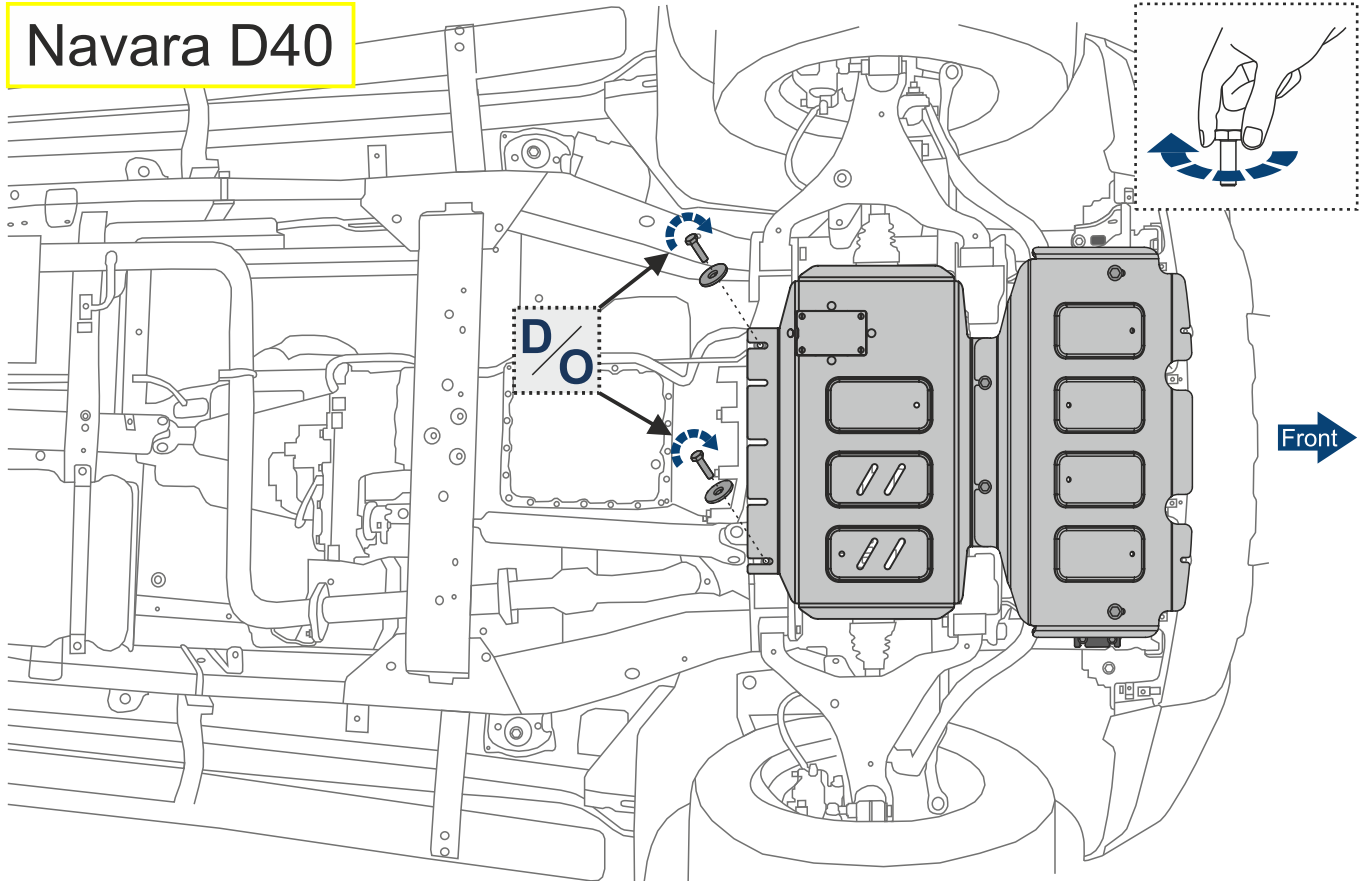

Navara D23

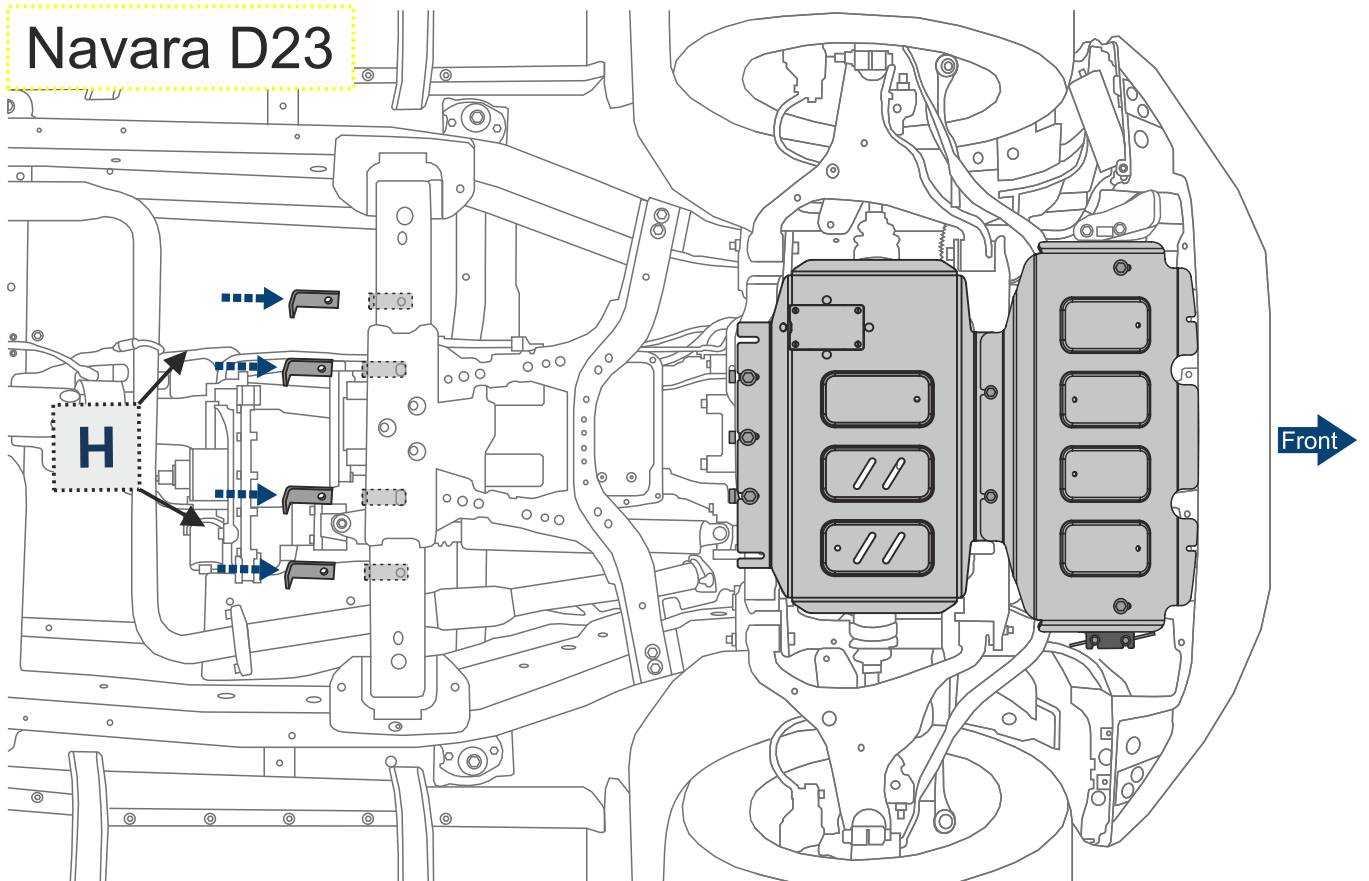

Navara D23

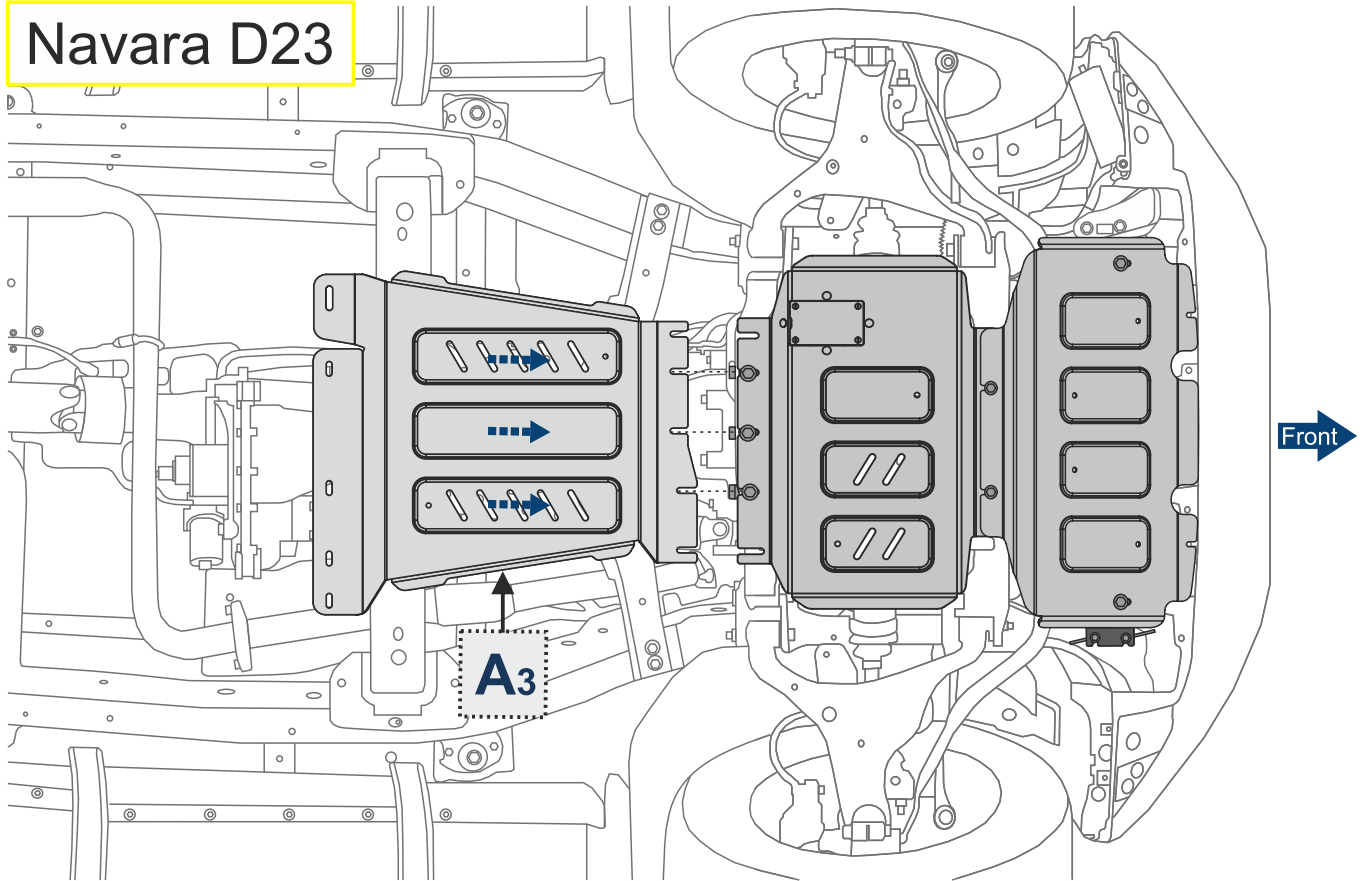

Navara D23

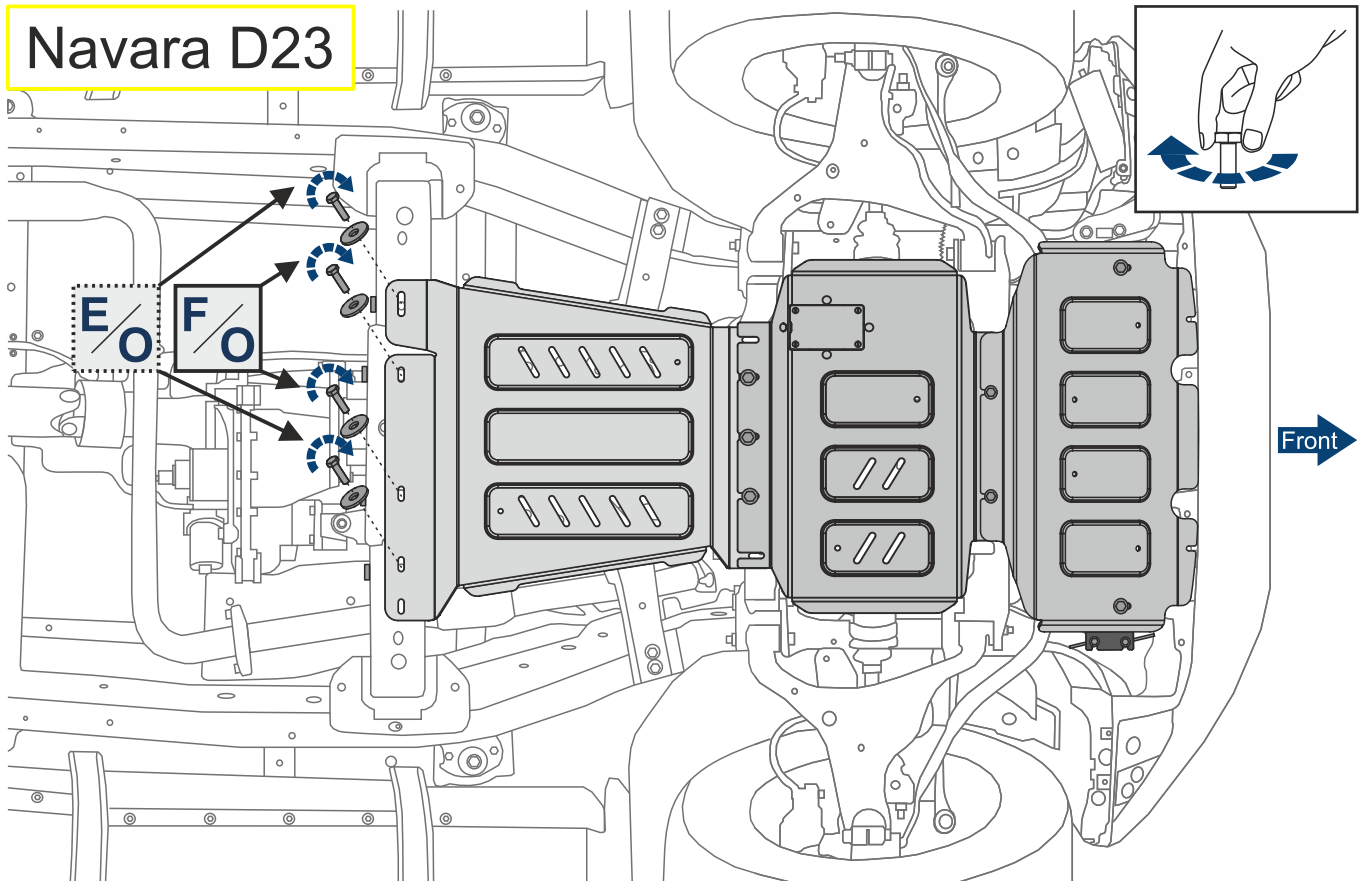

Navara D40

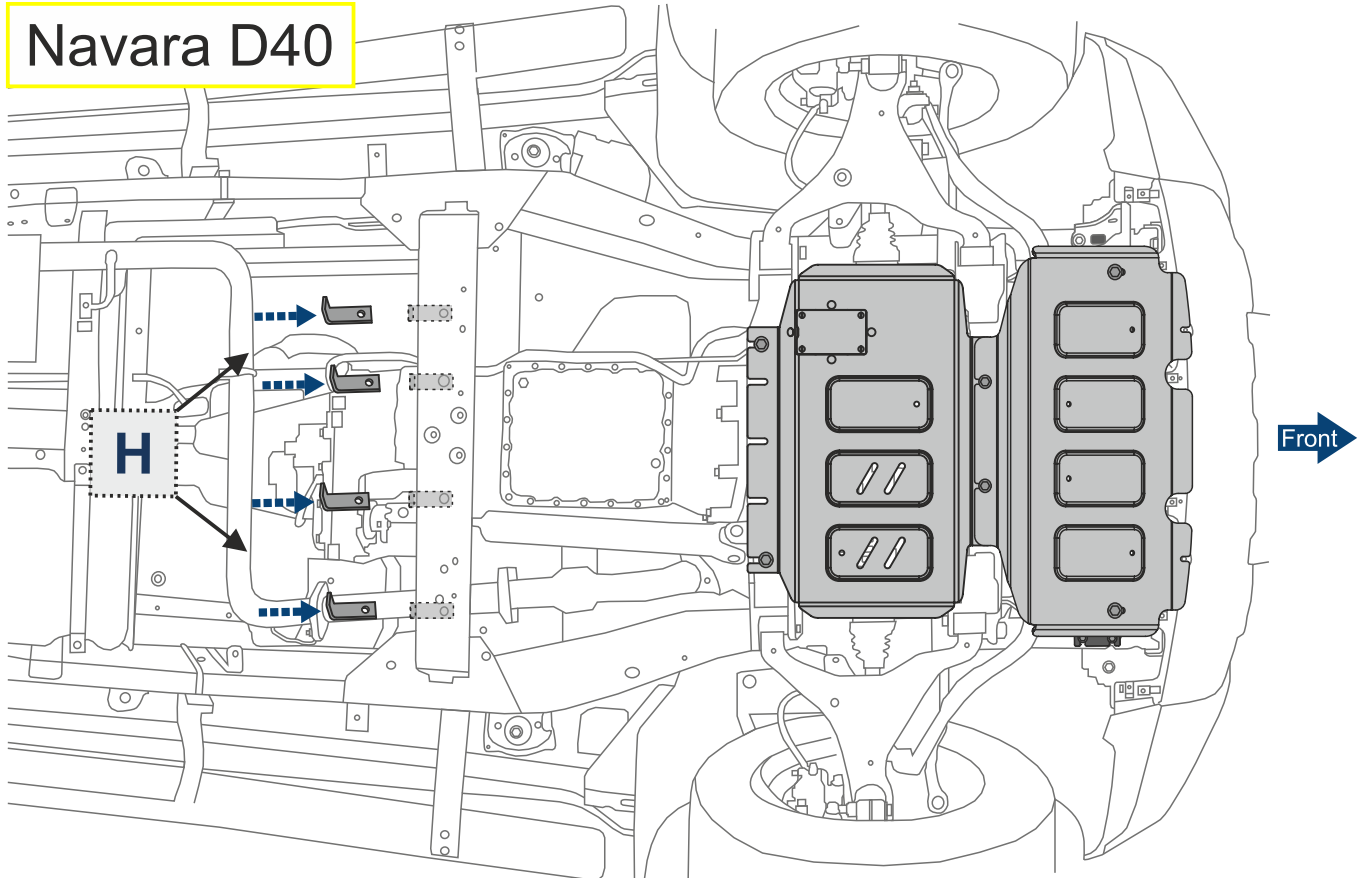

Navara D40

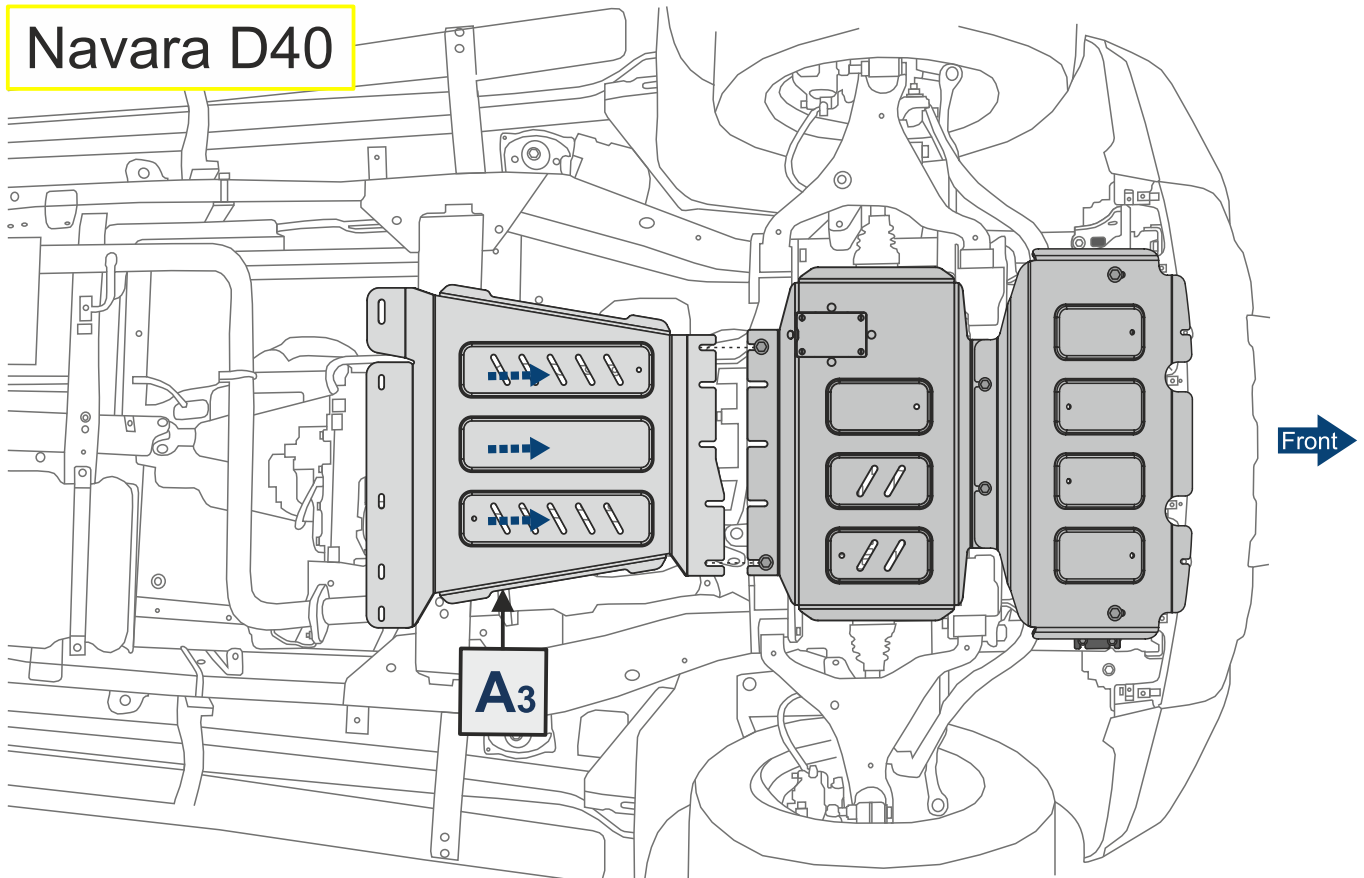

Navara D40

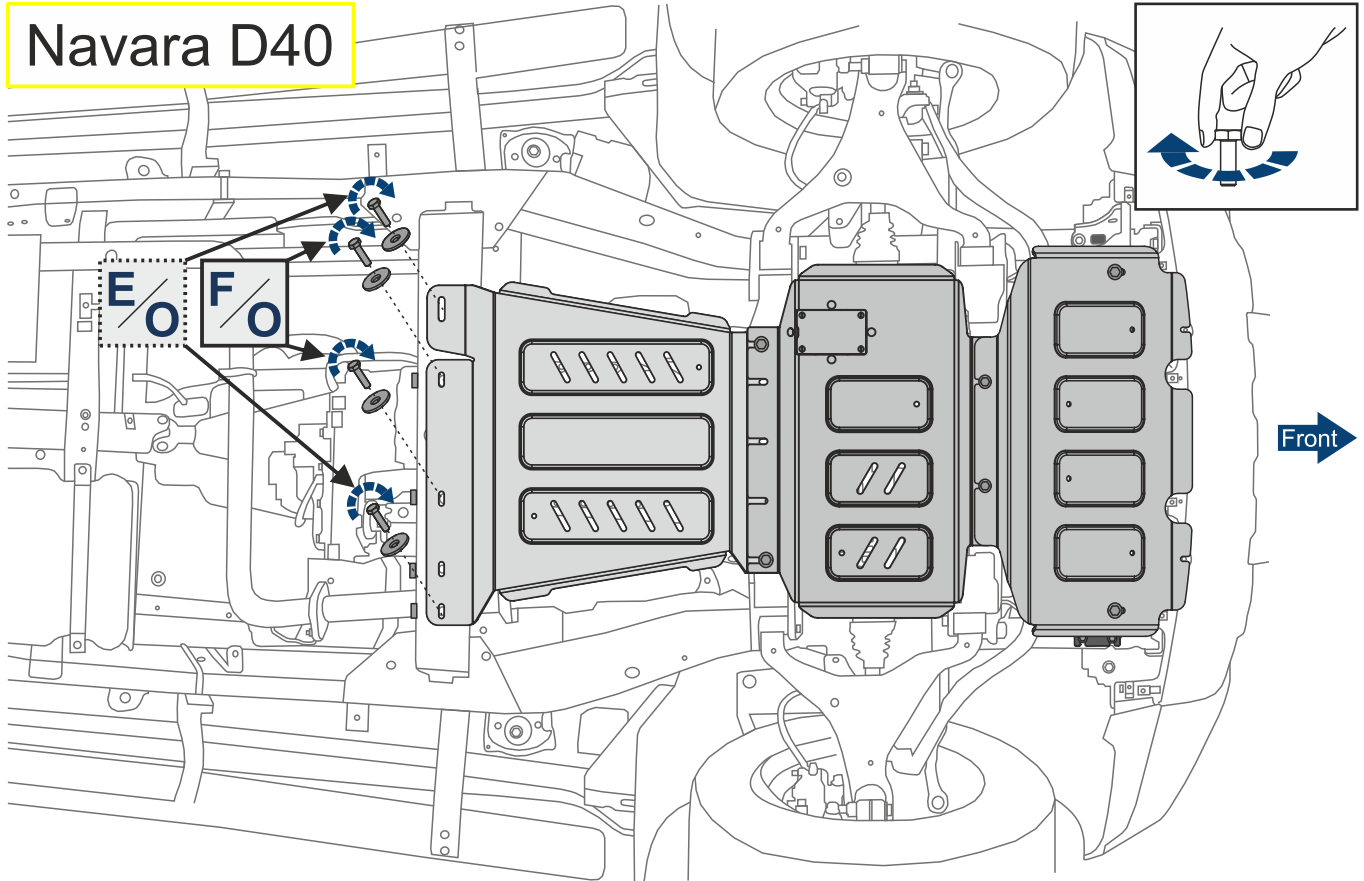

Navara D23/D40 3.0D

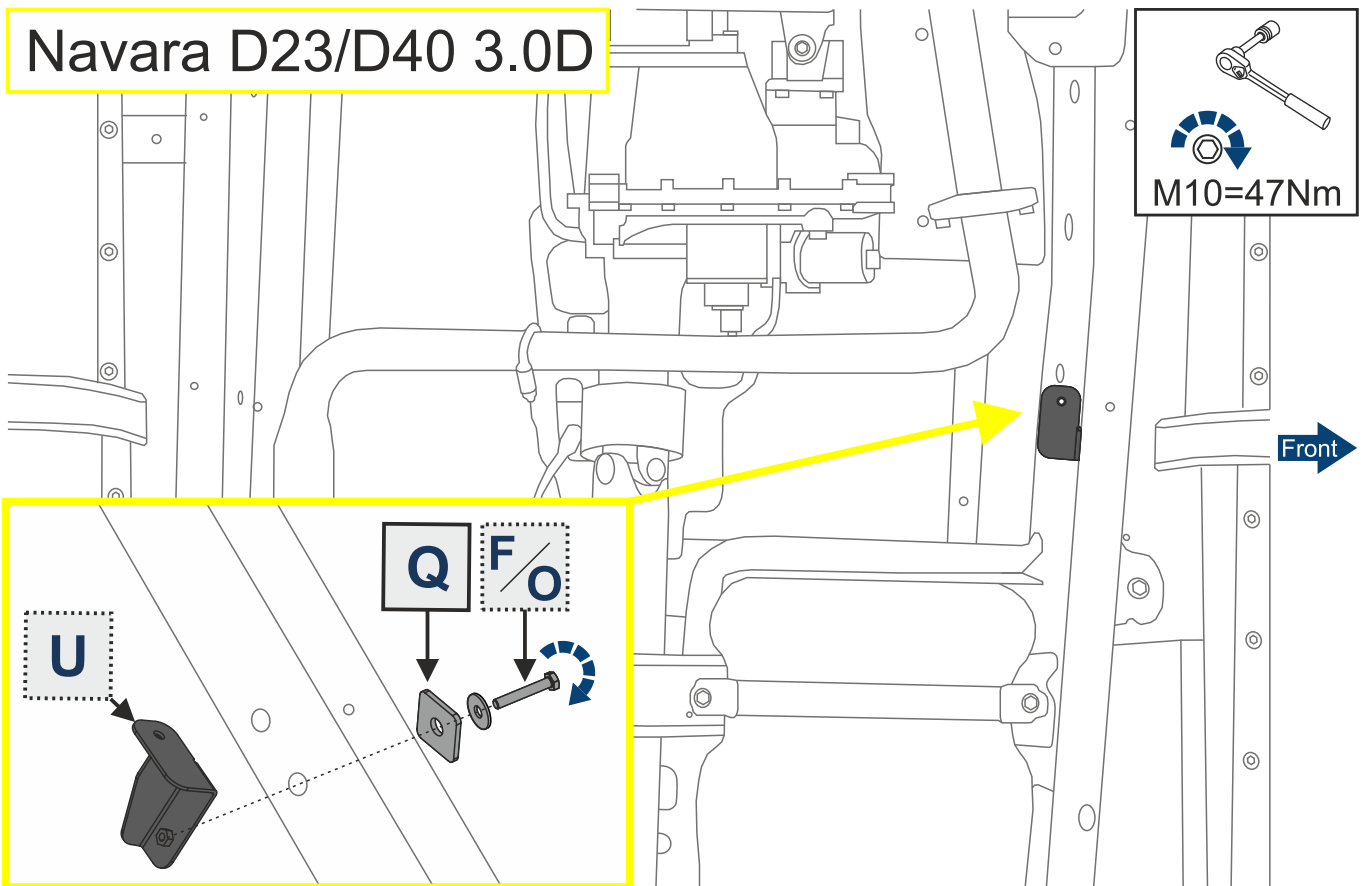

Navara D40 2.5D

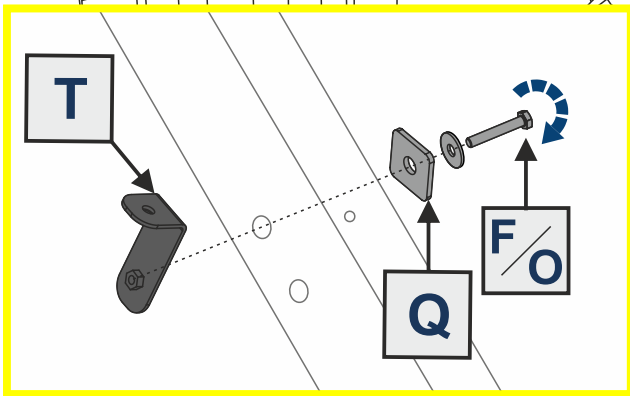
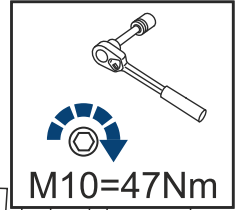

Navara D23/D40

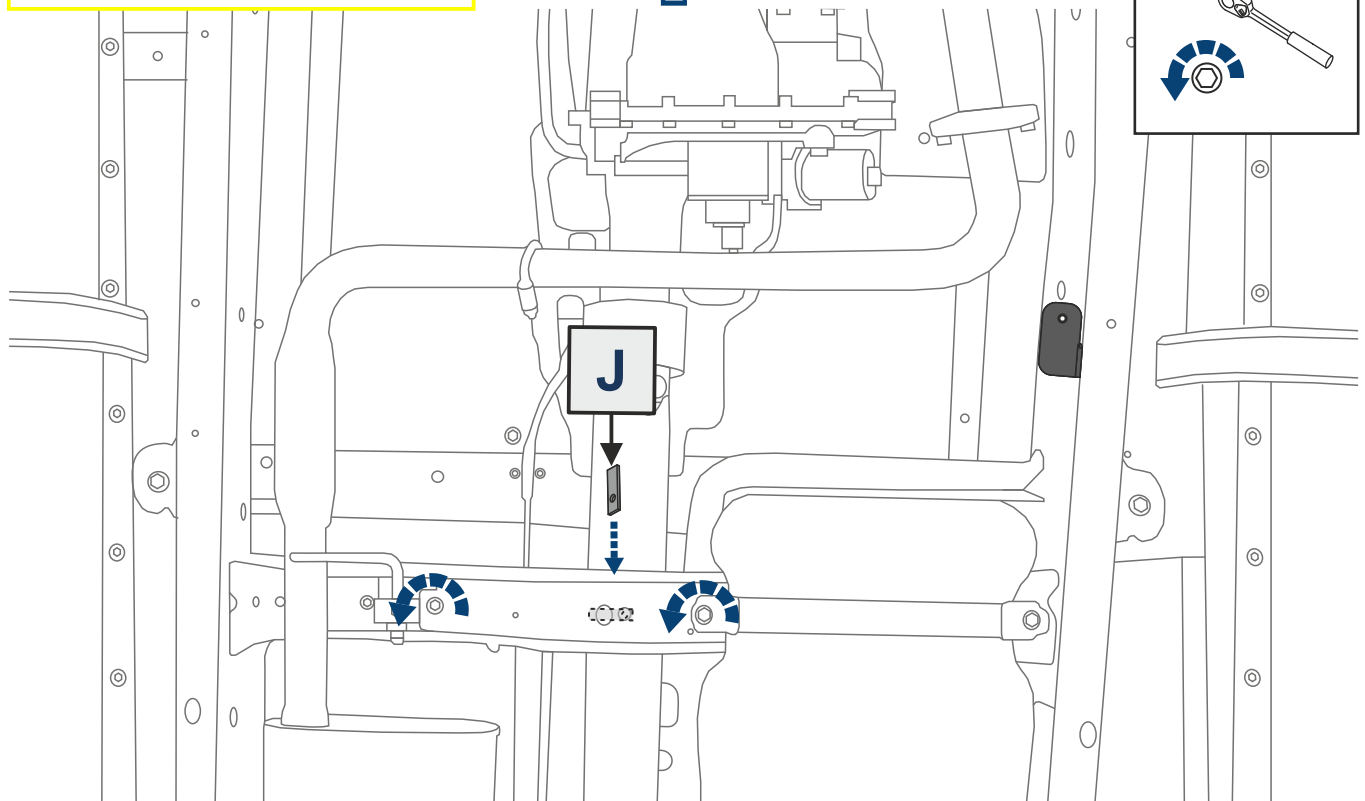
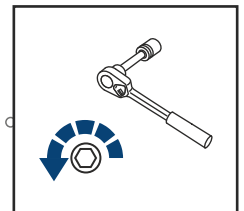

Navara D23/D40

Front ↑

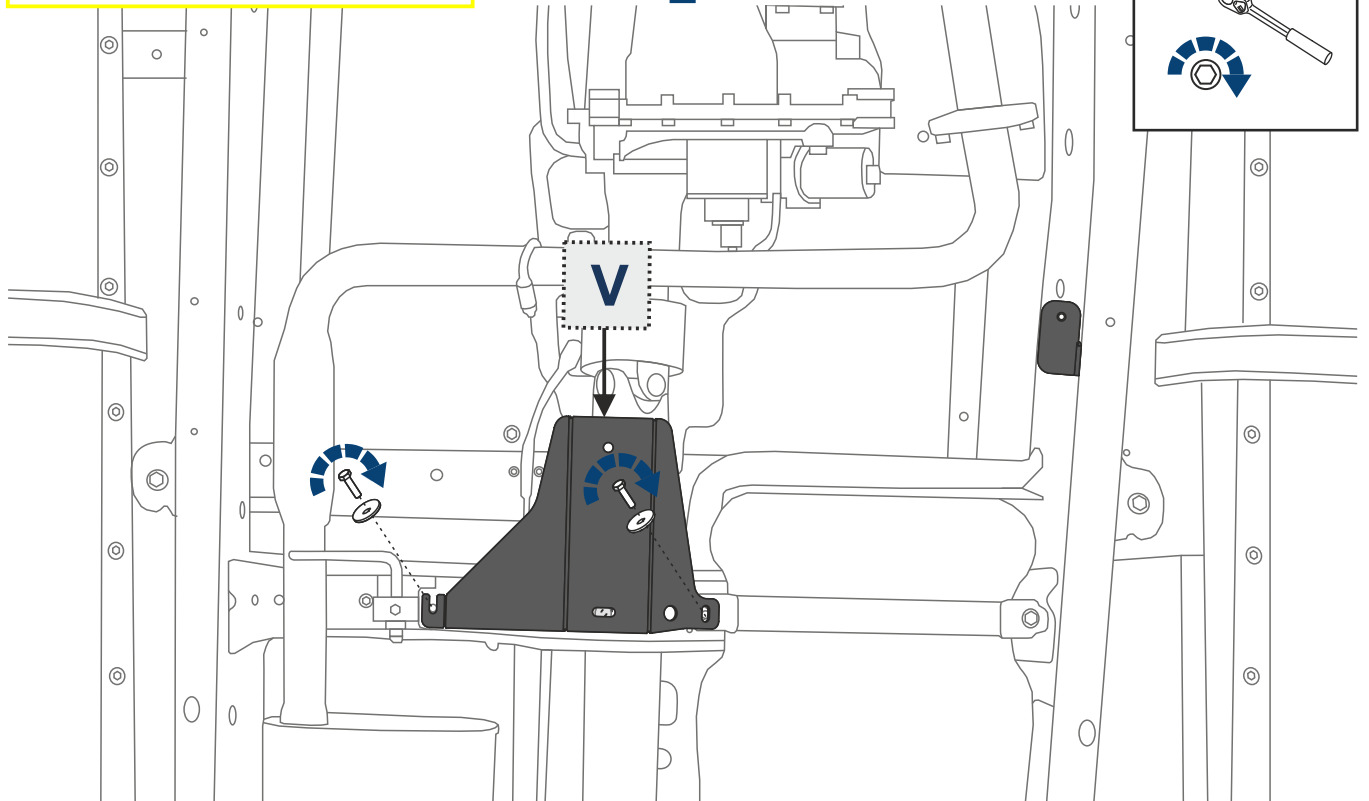

Navara D23/D40

Front ↑

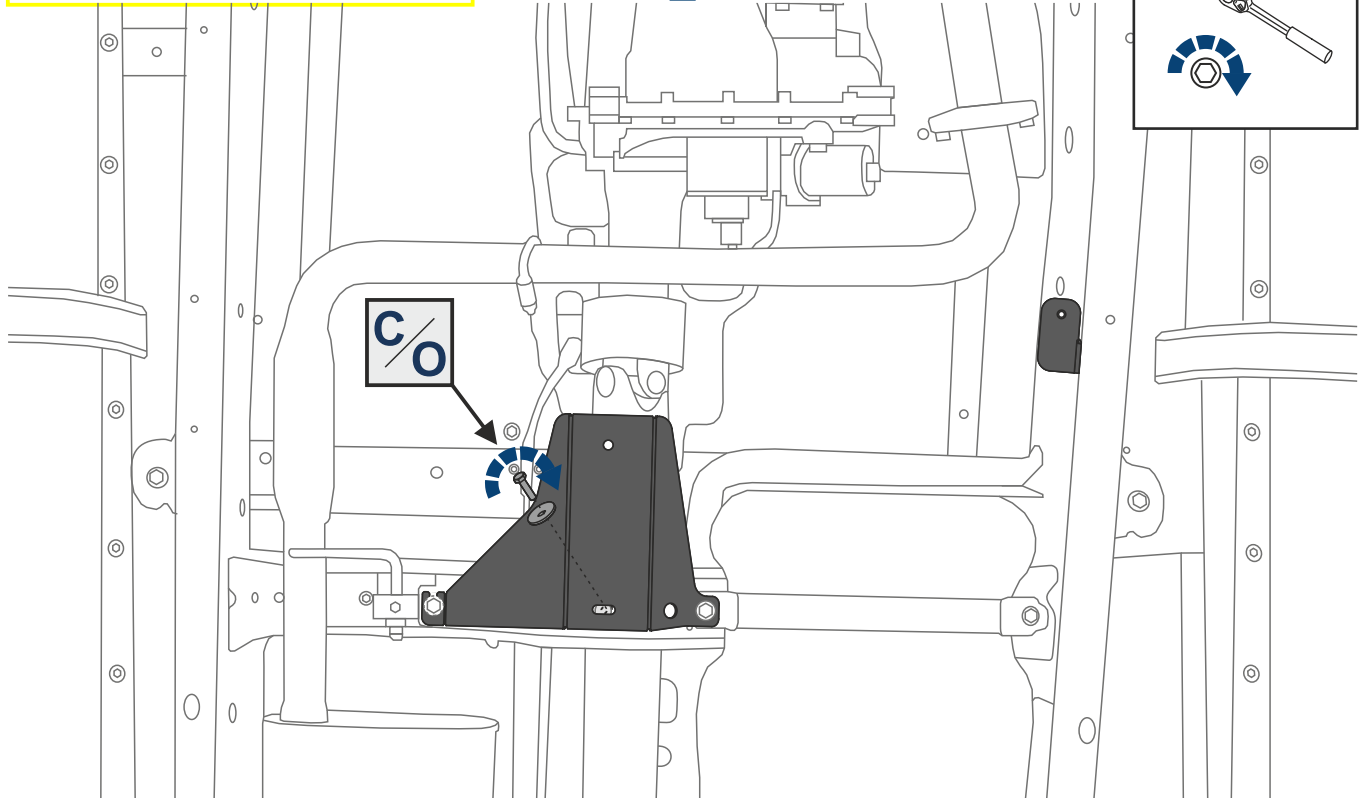

Navara D23/D40

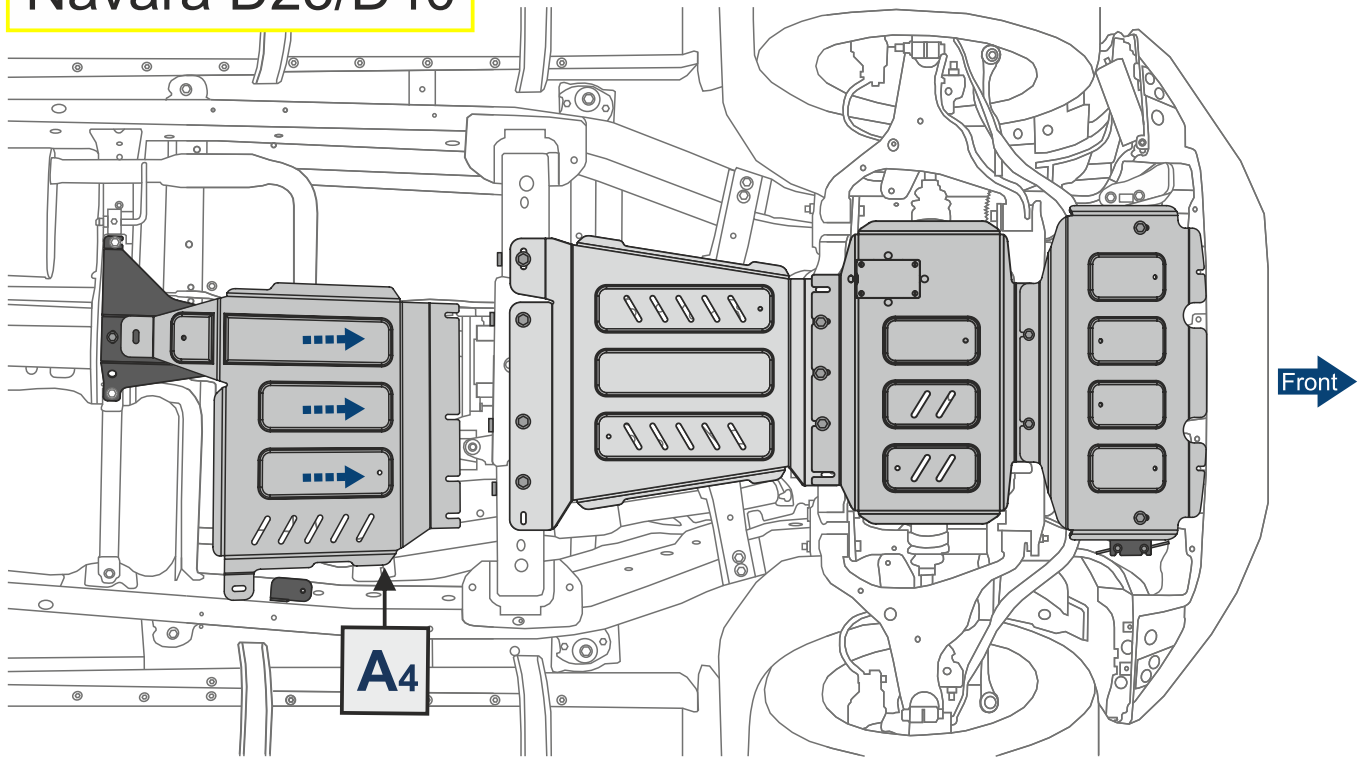

Navara D23/D40

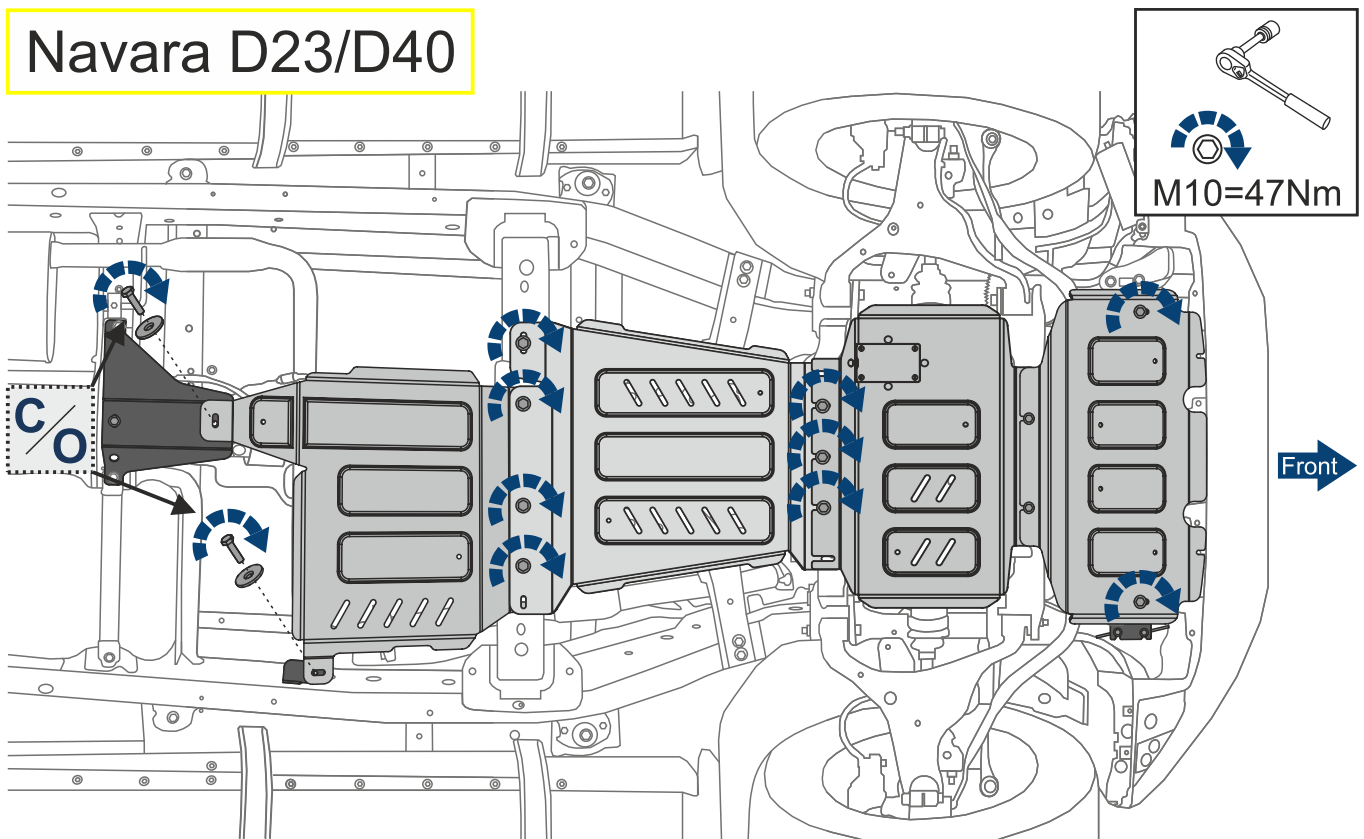

Navara D23/D40

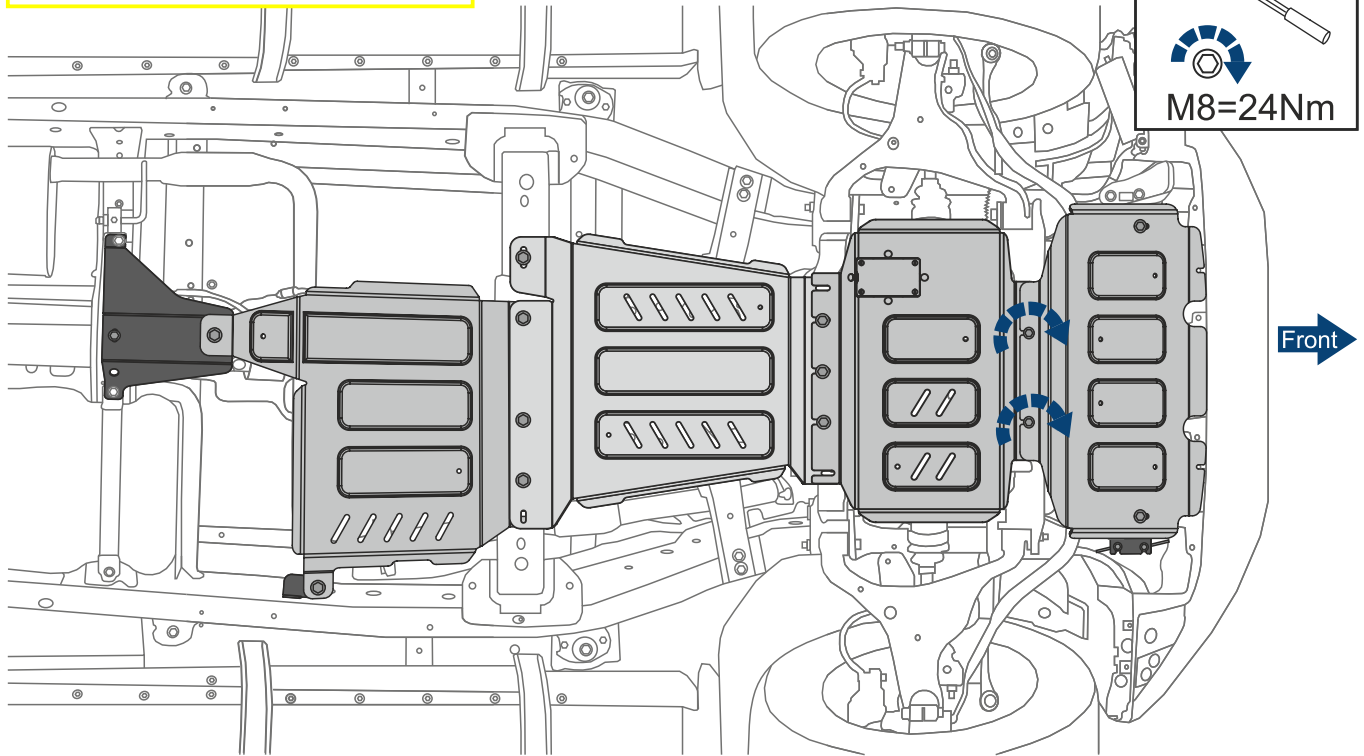

Navara D23/D40

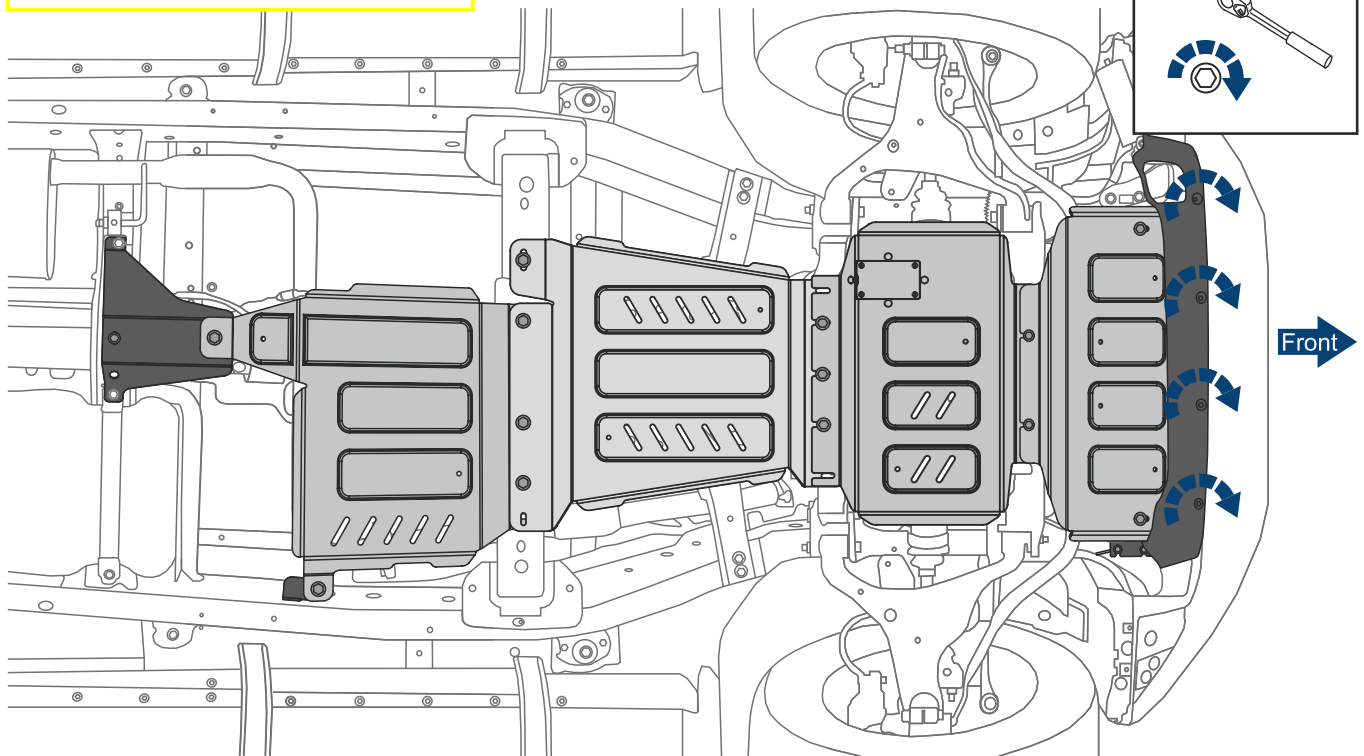

(RU) Установка:

Защита моторного отсека, топливного бака, редуктора и элементов трансмиссии разрабатывается индивидуально на каждый автомобиль.

Она должна устанавливаться в соответствии с инструкцией изготовителя специализированным дилером или на сертифицированных СТО.

Защита крепится к штатным отверстиям силовых элементов кузова.

При правильной установке защита не должна касаться узлов и агрегатов автомобиля.

(GB) Mounting requirements:

Skid plate for Engine bay and Gearbox is developed individual for each car model.

Skid plate must be mounted according to installation manual by an authorized car dealer or by a special car repair stations.

Skid plate is to be installed to original points and holes of the power units of the car.

Installed properly skid plate doesn't scrape another parts and assembly of the car.

(DE) Montageanleitung:

Unterfahr- und Unterbodenschutz ist individuell für jeden Fahrzeug entwickelt.

Unterfahr- und Unterbodenschutz ist gemäß Installationseinleitung des Herstellers bei einem autorisierten Autohändler oder Werkstatt zu montieren.

Unterbodenschutz wird zu den originalen Befestigungsbohrungen der Karosserieteilen montiert.

Korrekte Montierung bedeutet keine Stöße in dem inneren Motorenraum des Fahrzeuges.

(RU) Условия эксплуатации:

Защита моторного отсека и элементов трансмиссии предназначена для эксплуатации в условиях предусмотренных производителем автомобиля.

При эксплуатации должны быть исключены случаи наезда на крупные препятствия и предметы при движении автомобиля на скорости.

В случае наезда на препятствие необходимо убедиться в отсутствии повреждений узлов и агрегатов автомобиля и пригодности дальнейшей эксплуатации защиты на специализированном СТО.

(GB) Working requirements:

Skid plate for Engine bay and Gearbox is designed for use and drive of the vehicle in conditions considere by the car manufacture.

While driving the carat speed, cases of collisions with large obstacles and objects need to be excluded.

In the case of a collision with an obstacle skid plate and the vehicle must be inspected in a specialized car repair stations for damage of the components and assemblies and suitability for further use.

Betriebsanforderungen:

(DE)

Unterfahr- und Unterbodenschutz ist gemäß Betriebsanforderungen des Fahrzeugherstellers anzuwenden.

Auffahren auf die großen Behinderungen und Objekten beim Betrieb ist auszuschließen.

Beim Auffahren auf die Behinderungen und Objekten ist es nötig Mangel der Schädigungen und die Möglichkeit der weiterer Nutzung des Fahrzeuges beim autorisierten Autohändler oder Werkstatt zu prüfen.

(RU) Гарантия:

Гарантийный срок эксплуатации - 12 месяцев.

(GB) Warranty:

Warranty period - 12 months.

(DE) Gewähr:

Gewährperiode beträgt 12 Monaten.

(RU) Условия предоставления гарантии:

Защита установлена на автомобиль, с неповрежденными силовыми элементами кузова и конструкции (автомобиль, который не участвовал в ДТП);

Отсутствуют механические повреждения защиты, полученные в результате наезда на препятствие;

Соблюдены все требования инструкции по установке защиты;

Отсутствуют механические повреждения порошкового покрытия;

Производитель не несет ответственности за любой ущерб, причиненный автомобилю, жизни и здоровью людей, в случае нарушения условий установки и эксплуатации защиты.

Производитель вправе вносить изменения в конструкцию защиты.

(GB) Warranty terms and conditions:

Skid plate is installed on the car, with good condition of the body and the assembly parts (the car, that was not involved in the accident).

Absence of mechanical damages of the skid plate caused by a head-on crush;

Compliance with all installation requirements;

Absence of powder coating damages of the skid plate;

The manufacturer is not liable for any damage caused to the vehicle, the life and health of people in the event of breach of the installation and using of skid plate. The manufacturer has the right to change the design of skid plate.

(DE) Gewährleistung:

Unterfahr- und Unterbodenschutz ist an dem Fahrzeug ohne Schaden oder Änderungen in Karosseriebau und Karosserieteilen zu montieren.

Alle mechanische Schädigungen wegen Auffahren auf die Behinderungen sind entfallen.

Alle Anforderungen der Installationseinleitung sind berücksichtigt.

Schaden und Kratzspuren der Pulverbeschichtung sind entfallen.

Hersteller nimmt keine Haftung für jedweder Fahrzeugsschaden, Lebens- und Gesundheitsgefahr wegen Verwirkung und Durchbrechung der Montage- und Betriebsanforderungen.

Hersteller darf Design und Konstruktion der Unterfahr- und Unterbodenschutzen ändern.

Вся продукция сертифицирована

All products are certified

Alle Produkte sind zertifiziert

